

# ACCESS AUDIT REPORT & ACTION PLAN FOR ENHANCING ACCESSIBILITY OF BUILT UP ENVIRONMENT OF RAM LAL COLLEGE



Making Way for The Specially Aabled

राम लाल आनंद महाविद्यालय  
दिल्ली विश्वविद्यालय  
सूचना विभाग  
दिल्ली-110021

राम लाल आनंद महाविद्यालय  
RAM LAL ANAND COLLEGE

S. Benito Juarez Marg  
South Campus  
New Delhi-110021  
UNIVERSITY OF DELHI

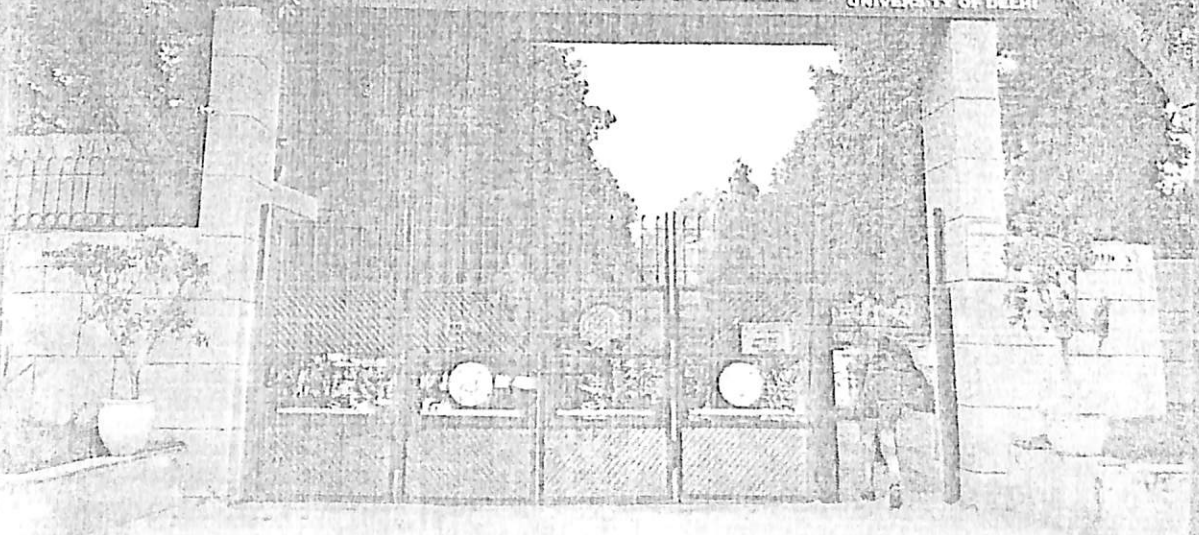

PREPARED BY

MAIARA TECHNOLOGIES,  
ACCESS AUDITS, CONSULTATION, PROJECT EXECUTION  
A, 1204 RUSTOMJEE ORIANA, NEAR MIG CRICKET CLUB,  
BANDRA EAST, MUMBAI 400051.  
EMAIL US @  
TEL: No : +91 9867259993  
VISIT US @ WWW.MAIARATECH.COM



# AUDIT PRINCIPLES & APPROACH

A universal design strategy has been applied to every part and the whole of the site , while formulating the recommendations for enhancing Universal Accessibility at the site.

The aim is to achieve the following goals wherever practicable:

Pre-visit information available in accessible formats and providing information about the accessibility of the site and services.

Staff and guides trained in disability and equality awareness.

Well designed and legible signage.

An accessible principal entry point.

An accessible external landscape.

Simple and intuitive way finding and orientation.

Access for everyone to all parts of site or, where this is not possible, alternative access provided.

Information available in a variety of formats.

Accessible visitor facilities and public conveniences.

Emergency evacuation for everyone.

Auditory Signals.

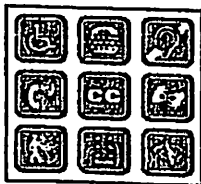

"Accessibility"  
Providing access to ALL.



Application of universal  
design principles for  
social sustenance.

## MAIN CONSIDERATIONS:

1. Comprehensive Study and Graphical Summary of Key findings.
2. Stress on assessment of finer details of Site planning, Architectural design of building elements, Materials and Finishes .
3. Usability of Built Environment keeping in mind PwD's as pedestrians / users.
4. Disaster Preparedness and Evacuation Provisions.

## AUDIT PRINCIPLES & APPROACH

A universal design strategy has been applied to every part and the whole of the site , while formulating the recommendations for enhancing Universal Accessibility at the site.

The aim is to achieve the following goals wherever practicable:

Pre-visit information available in accessible formats and providing information about the accessibility of the site and services.

Staff and guides trained in disability and equality awareness.

Well designed and legible signage.

An accessible principal entry point.

An accessible external landscape.

Simple and intuitive way finding and orientation.

Access for everyone to all parts of site or, where this is not possible, alternative access provided.

Information available in a variety of formats.

Accessible visitor facilities and public conveniences.

Emergency evacuation for everyone.

Auditory Signals.

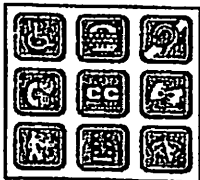

"Accessibility"  
Providing access to ALL.



Application of universal  
design principles for  
social sustenance.

### MAIN CONSIDERATIONS:

1. Comprehensive Study and Graphical Summary of Key findings.
2. Stress on assessment of finer details of Site planning, Architectural design of building elements, Materials and Finishes .
3. Usability of Built Environment keeping in mind PwD's as pedestrians / users.
4. Disaster Preparedness and Evacuation Provisions.

# ACCESSIBILITY THE LEGAL FRAMEWORK.

## The Legal Framework

The importance of promoting greater access as an effective approach to reversing exclusion and enhancing the equalization of opportunities in a sustainable way has been the mandate of the

*United Nations Convention on the Rights of Persons with Disabilities* (UNCRPD), approved by the General Assembly in December 2006,

ratified by India on October 1, 2014 and which entered into force in May, 2008.

The Convention also mandates that all Governments shall take measures for implementation of minimum standards and guidelines for

accessibility of facilities and services open to the public; to ensure that private entities that offer facilities / services open to the public comply with all aspects of accessibility for persons with disabilities; train stakeholders on accessibility issues; provide Braille signage and live assistance, professional sign language interpreters to facilitate accessibility to buildings and other facilities open to the public.

Further, Goal No. 3 of the *Inchon Strategy*, which provides the Asian and Pacific Region and the world the first set of regionally agreed distinct inclusive development goals, mentions that access to the physical environment, public transportation, knowledge, information and communication is a precondition for persons with disabilities to fulfill their rights in an inclusive society.

Sections 40, 41, 45 and 46 of *The Rights of Persons with Disabilities Act 2016*, categorically provides for nondiscrimination in education, transport, the roads, built environments and information and technology.

Article 9 of the UNCRPD on "Accessibility" stipulates that persons with disabilities are to be enabled to live independently and participate fully in all aspects of life. The Article casts an obligation on all signatory governments to "...take appropriate measures to ensure to persons with disabilities access, on an equal basis with others, to the physical environment, to transportation, to information and communication, including information and communications technologies and systems, and to other facilities and services open or provided to the public, both in urban and in rural areas....."



# ACCESSIBILITY OF BUILT UP SPACES

## ACCESS AUDIT:

### **Purpose of an access audit:**

The purpose of an access audit is to assess how a particular building or environment performs in terms of access and ease of use by a wide range of actual and potential users, including person with disabilities and to recommend access improvements. The aim of the access audit and its follow-up are to:

Identify the extent of the problem of access to public buildings and recommend changes additions to make the environment accessible  
To create awareness of the importance of the concept of barrier-free environments for persons with disabilities

To enforce the inclusion of accessibility for persons with disabilities in the official agenda of government and private agencies.

The report includes observations, measurements, sketches and photographs covering all parts of the public building audited including the external and internal environment as well as the services provided in the building.

### OBJECTIVE:

The objective of the campaign is to create mass awareness for accessibility, which will enable persons with disabilities to live independently and participate fully in all aspects of life. The buildings being audited shall be judged for the accessibility based on standards and the identified barriers will be looked into to enhance accessibility.

### STANDARDS:

The accessibility standards and parameters adhered to in the instant access audit are as per the revised guidelines (2016) of the Central Public Works Department Manual, *Handbook on Barrier-Free and Accessibility* (URL: <http://cpwd.gov.in>)

For some points not specifically covered by the said Handbook, reference has been taken from the *Harmonized Guidelines and Space Standards for Barrier Free Built Environment* of the Ministry of Urban Development Government of India.

## EXECUTIVE SUMMARY



---

Name of the Building : Ram Lal College.

Building Type & Use : Educational Complex.

Name of the Executive Engineer : R K Garg

---

### **BUILDINGS COVERED IN THE REPORT**

Ram Lal College Delhi University.

# EXECUTIVE SUMMARY



---

Name of the Building : Ram Lal College.

Building Type & Use : Educational Complex.

Name of the Executive Engineer : R K Garg

---

## BUILDINGS COVERED IN THE REPORT

Ram Lal College Delhi University.

## EXTERNAL ENVIRONMENT – APPROACH GATES

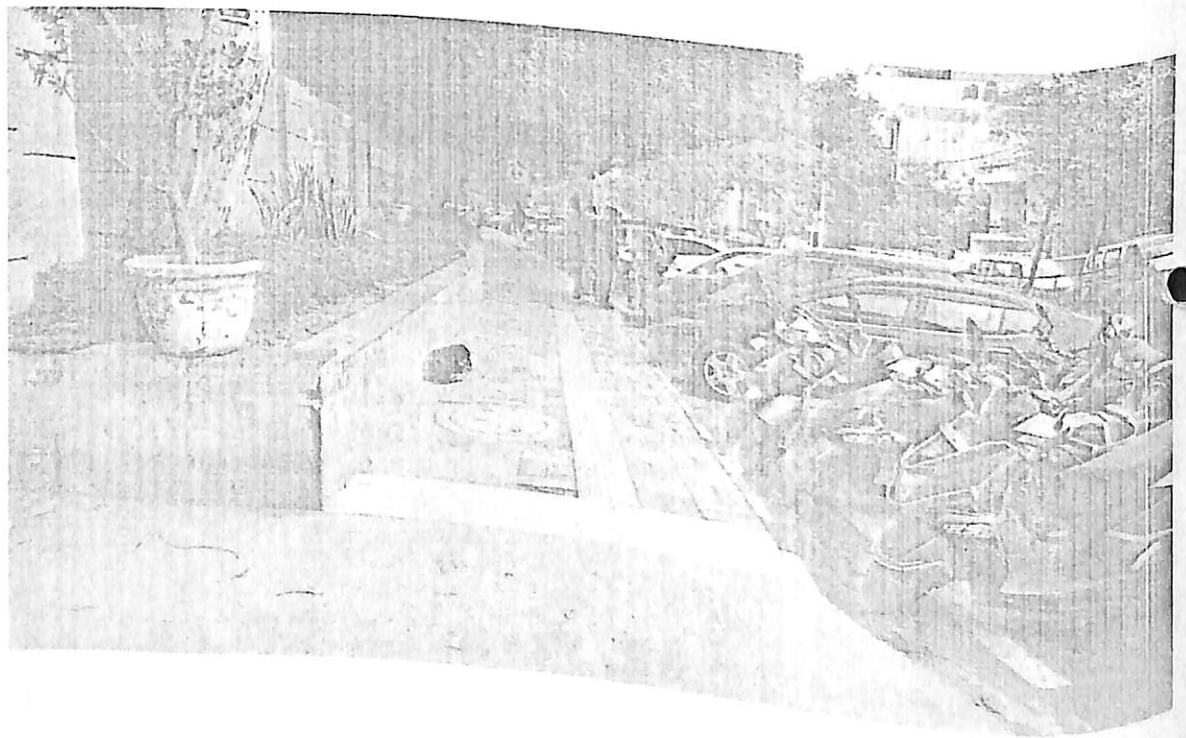
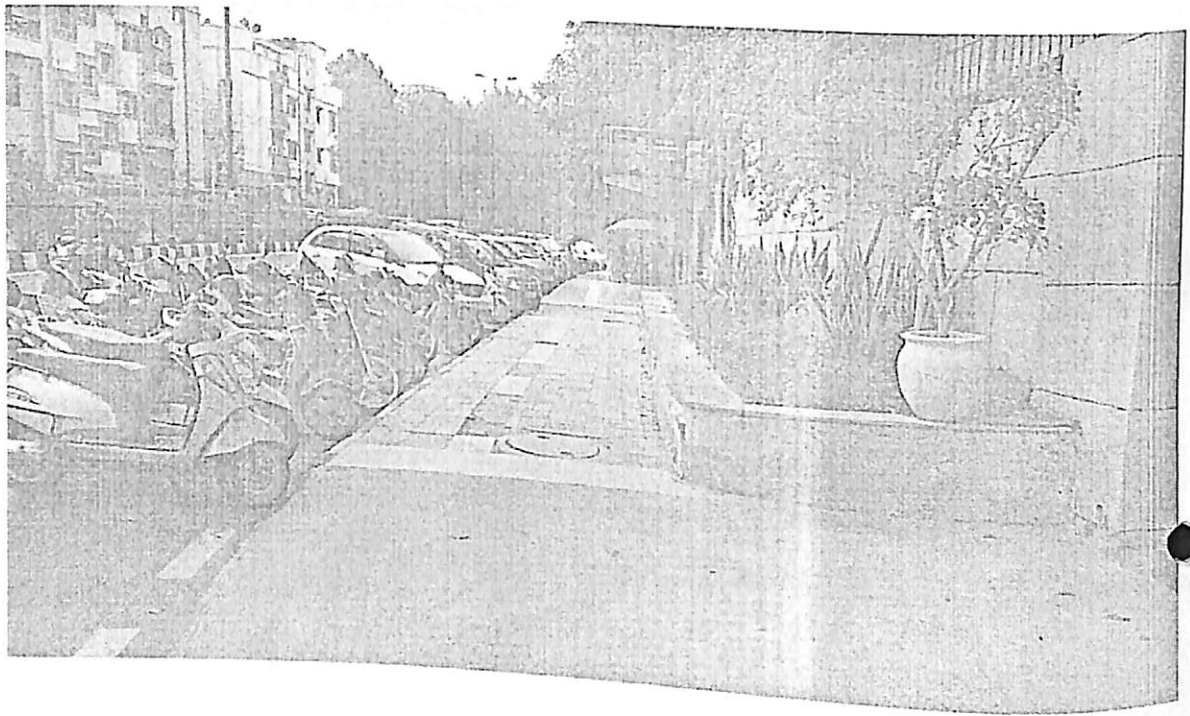

## **EXTERNAL ENVIRONMENT – APPROACH GATES**

### **Observations and suggestions :**

- ❖ **Approach to College is Through Main road and is accessible by a private vehicle / Taxi / Auto, the Public transport leads to the entrance of the complex and Directional signs shall be put up the principal point of entry to the Building.**
- ❖ **Footpaths are present on the road however the footpath does not have the Kerb ramps on either sides, at some places kerbs are present but they are not as per standards, also they are poorly maintained, these are used by people with disabilities and shall be strictly maintained and shall be obstacle free.**
- ❖ **There is No Accessible Building Entrance Signage, Audio Tactile Layout, Audio Beeper, Tactile path till the entrance and further to the principal point of entry to the building is present partially but the tactile tiles are not as per specifications, Tactile layout of the every premises is missing and must be installed.**
- ❖ **Audio beeper may be provided at the entrance for signaling to visually impaired people.**
- ❖ **Footpaths must adhere to the standards of min of 1200 mm clear width, not more than 6" in height with kerbramps and tactile path as per guidelines provided in standards to be installed. Tactile tiles be Preferably of 60 mm thick CC Tiles.**
- ❖ **Ideally Pedestrian Traffic and vehicular traffic shall be separated at the principal point of Entry to the building.**

## APPROACH / EXTERNAL ENVIRONMENT

- ❖ The principal public entry point to the building should be made accessible.
- ❖ Provision of a large eye-catching road sign showing visitors the direction to the site's main entrance.
- ❖ Provision of Accessible path for PWD's from entrance gate to the building entrance.
- ❖ Footpath to be provided on both sides of the entrance gate.
- ❖ Provide Kerb ramps in footpaths where the accessible path intercepts with road / kerbs.
- ❖ Provide tactile guiding path in the footpath and at the entrance for independent navigation for PwVI.
- ❖ Following two types of tactile guiding surface indicator (TGSI) should be provided to guide and alert PwVI.
- ❖ **Directional tile:** It consists of raised parallel bars to guide people along the direction of a tactile path.
- ❖ **Warning tile:** It consists of raised truncated domes arranged in square grid Parallel to the sides of the tile to alert people of potential hazards such as top and bottom of stairs, door openings and at pedestrian crossings.
- ❖ Trees on footpaths to be provided with a grating cover and guardrails as shown in the detail on following page. Ensure no obstacles are present on footpath.
- ❖ Provide beeper or audio signal at entrance gate.
- ❖ A tactile pictographic map of the campus to be provided at the gate.
- ❖ The staff at the security cabin and the entrance gate to be trained to assist people with disabilities.
- ❖ Accessible directional, multilingual and tactile signage to be provided as per standards.
- ❖ Grating provided if any should have spaces not greater than 13 mm wide in one direction to avoid trapping of crutches or wheels, and be placed so that Channel grating slots should not be parallel to the traffic direction as illustrated in fig. on following page.



## INTERNAL ENVIRONMENT INTERNAL APPROACH ROAD.

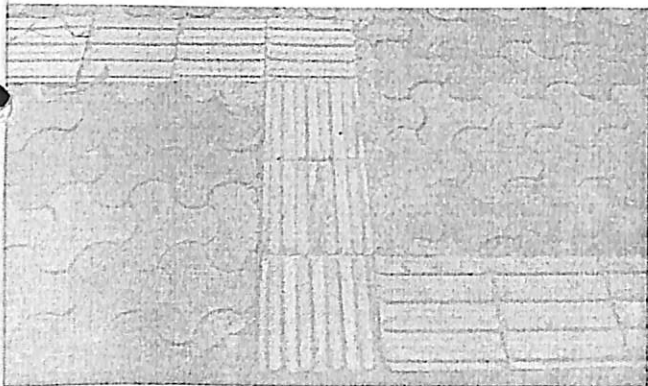
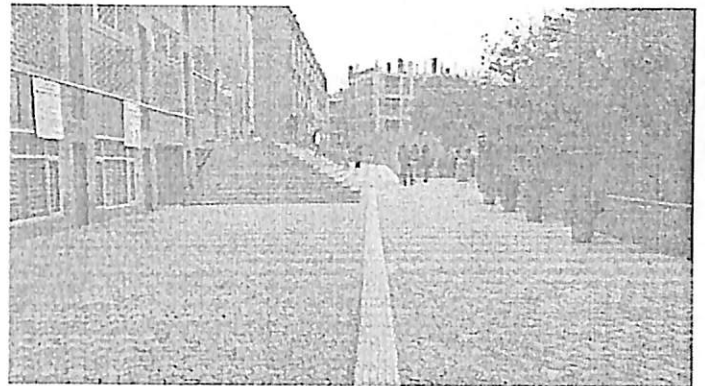
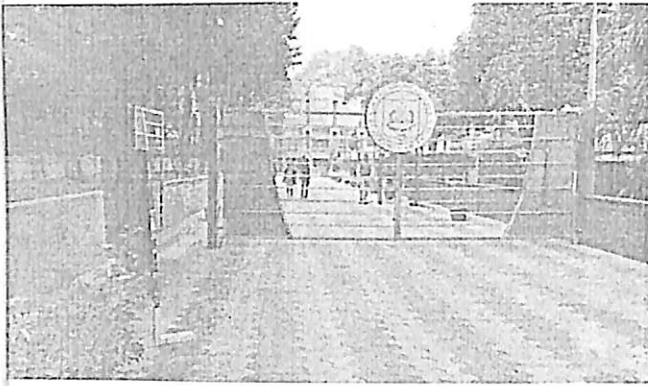

- ❖ There are pedestrian pathways around the building , Provision of Tactile Path is seen however they are not as per the guidelines, they need to be placed as per standards.
- ❖ The pathways are stepped in some places.
- ❖ Pathways are discontinuous/ unfinished / damaged in some places.
- ❖ Junctions between pathways of different material are not seamless.
- ❖ Resting Spaces Not provided for and paved pathways should be leading to resting benches.
- ❖ There is no tactile guiding path including directional, hazard warning and positional tiles provided for independent navigation across all the external pathways / landscape surrounding the site. Those found are dangerous and are a trip hazard to people who will use them.
- ❖ Kerbs are not provided to separate pathways from unused open spaces/ landscape spaces.
- ❖ There are no tactile warning blocks / kerbs / guardrails around trees / poles.
- ❖ There is no accessible directional signage. Mere placement of tactile path shall not create the accessible route.

## INTERNAL ENVIRONMENT INTERNAL APPROACH ROAD / SURFACES

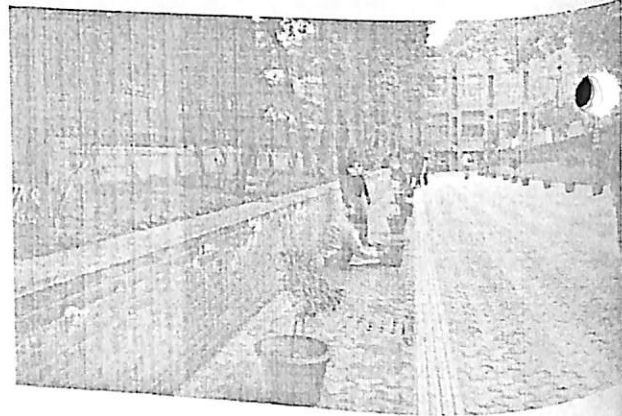
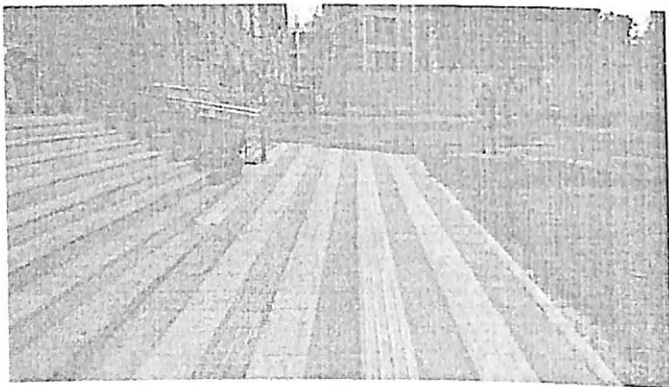
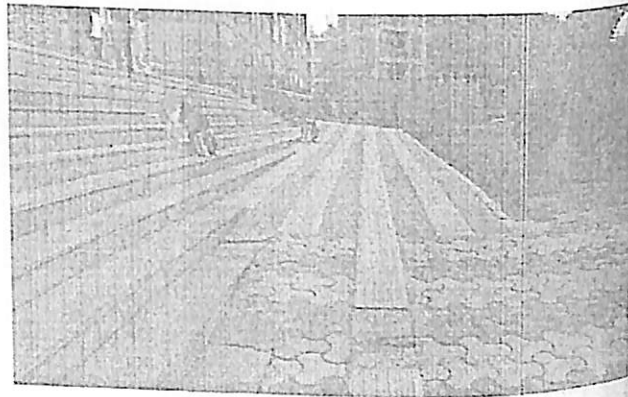

### Observations and Suggestions:

- ❖ Uneven surface near Manholes are found along the pedestrian walkways and are a trip hazard to the people with Disabilities, elderly people.
- ❖ There is no accessible directional signage on the path, tactile guiding path needs to be corrected at many spaces and no kerbs along the pathways.
- ❖ Accessible directional, multilingual and tactile signage to be provided as per standards leading to the accessible entrances.
- ❖ Provision of continuous accessible path for PWD's to reach the entrances of important building facilities in the Campus.
- ❖ Some approach roads are discontinuous they are to be provided for the complete accessibility status.
- ❖ Pots are placed on access route and they shall be moved away from the tactile path.



## INTERNAL ENVIRONMENT INTERNAL APPROACH ROAD / SURFACES

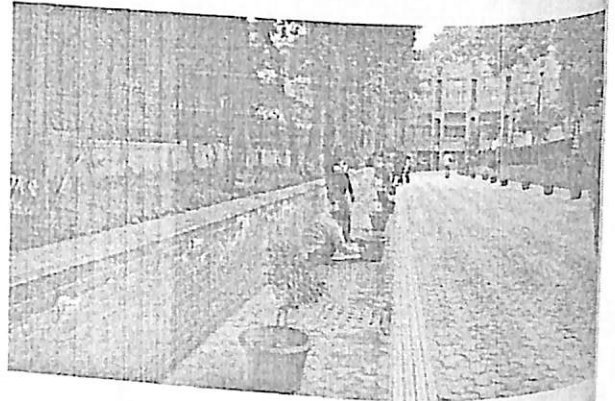
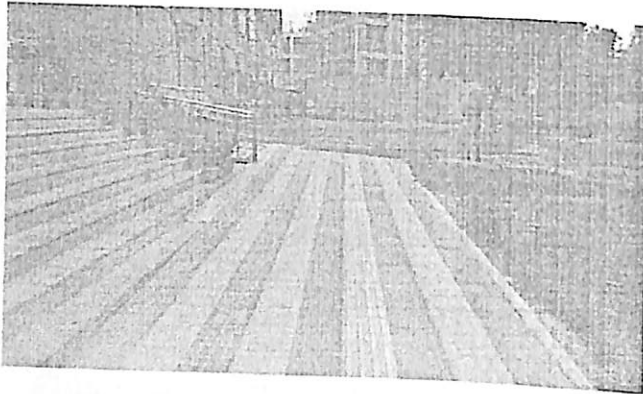
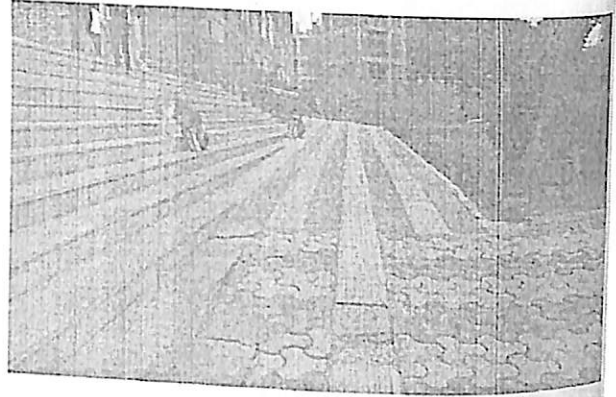

### Observations and Suggestions:

- ❖ Uneven surface near Manholes are found along the pedestrian walkways and are a trip hazard to the people with Disabilities, elderly people.
- ❖ There is no accessible directional signage on the path, tactile guiding path needs to be corrected at many spaces and no kerbs along the pathways.
- ❖ Accessible directional, multilingual and tactile signage to be provided as per standards leading to the accessible entrances.
- ❖ Provision of continuous accessible path for PWD's to reach the entrances of important building facilities in the Campus.
- ❖ Some approach roads are discontinuous they are to be provided for the complete accessibility status.
- ❖ Pots are placed on access route and they shall be moved away from the tactile path.

# APPROACH TO BLOCKS / ENTRANCE

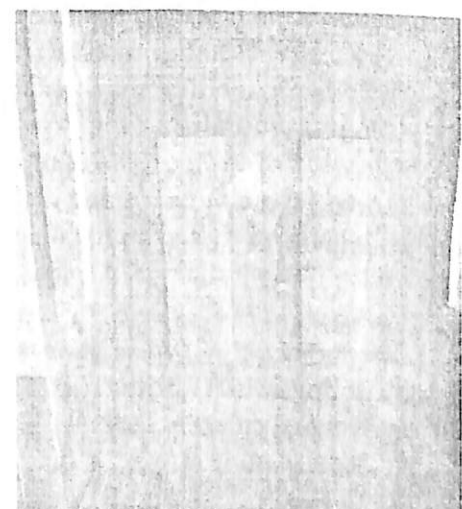
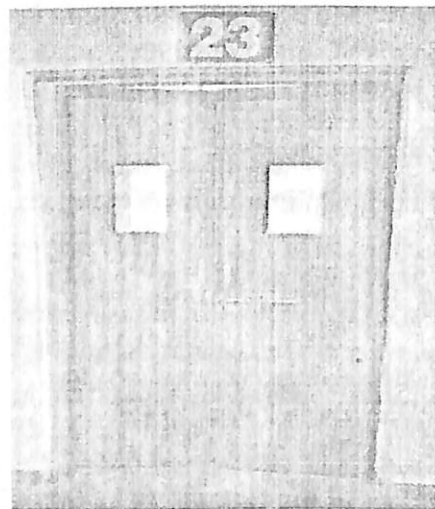
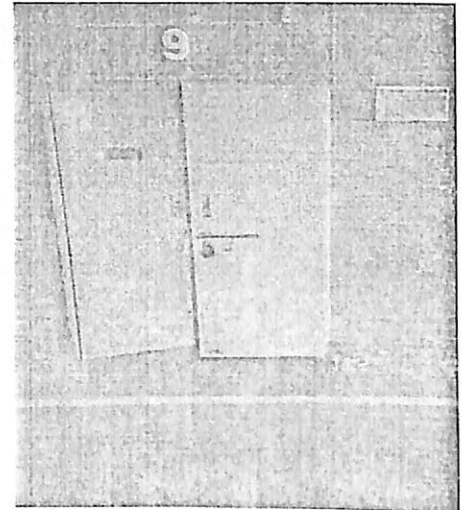
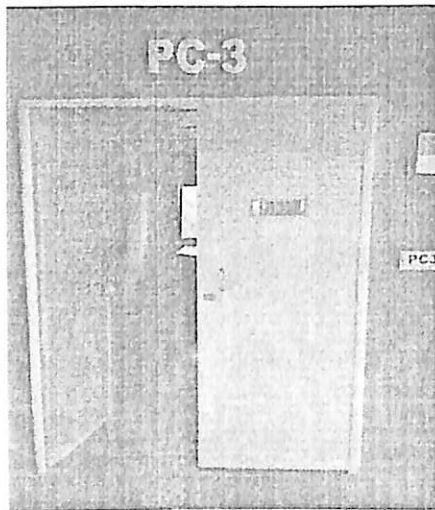
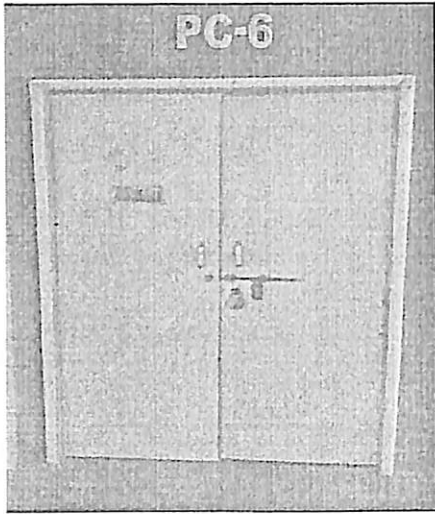

# APPROACH TO BLOCKS / ENTRANCE

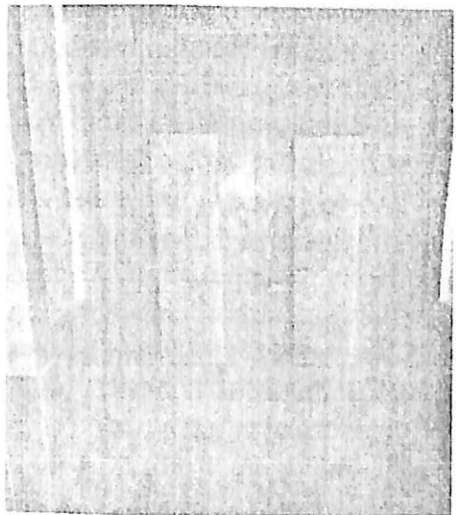
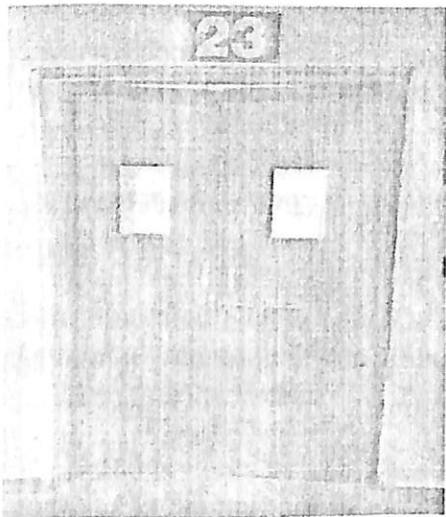
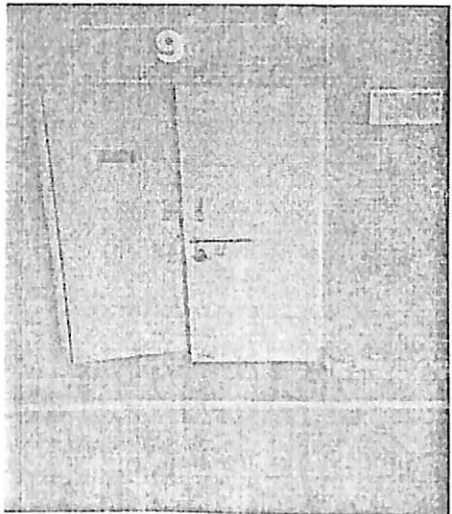
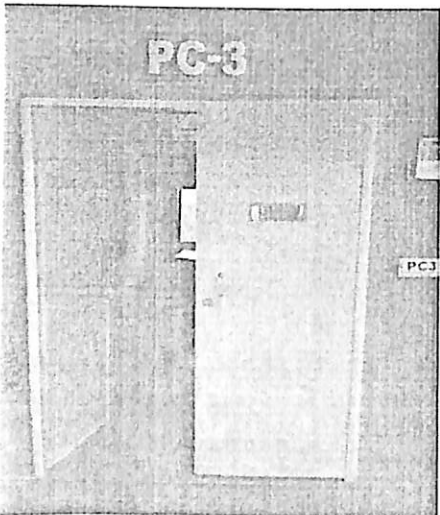
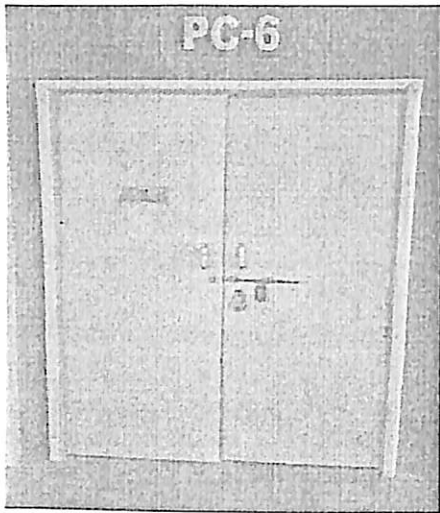

## INTERNAL ENVIRONMENT - ENTRANCE

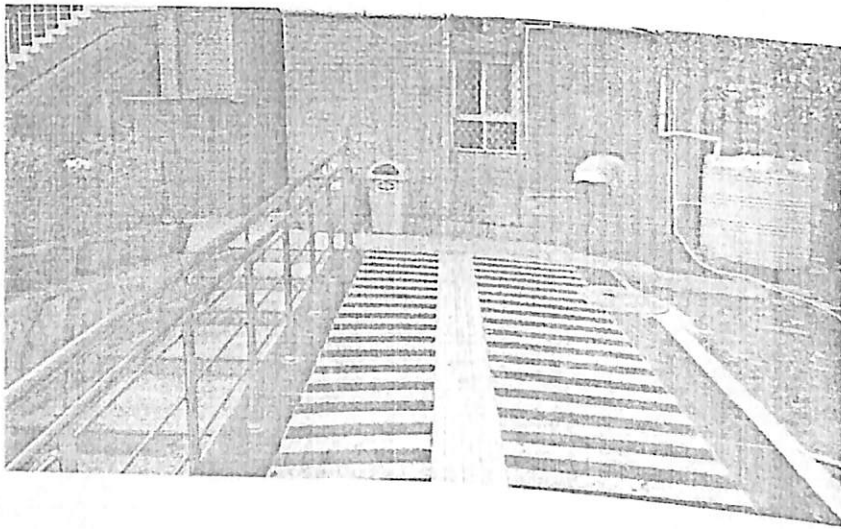
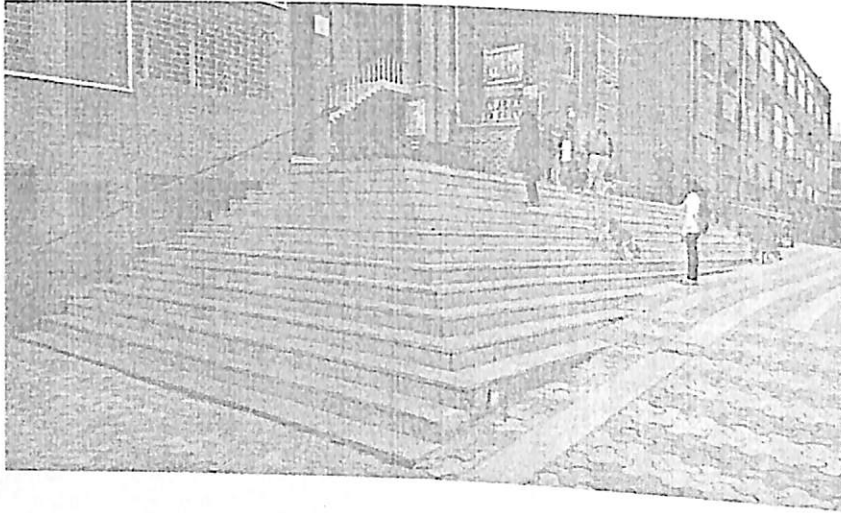

### Observations and Suggestions:

- ❖ The Principal entry to the Building is stepped, there is a ramp to the premises. Provision of Tactile Tiles (Positional / Tactile ) is provided, along with other suggestions. There shall be no obstruction to the principal point of Entry.
- ❖ Directional, positional, Warning tiles used by people with blindness and low vision are missing at some locations and may be provided.
- ❖ Ramps are to be constructed, please ensure that the Width of Ramp is 1200 mm- 1800 mm is suggested width.
- ❖ Provide Railings at ramps and the height of the railing is 900 mm and is from the Ground level and the other one at 750 mm.
- ❖ Braille hand rails are to be provided on railings.
- ❖ Signages leading to the Blocks are missing and may be provided as per the universal standards, accessible.
- ❖ Provide ramps at all stepped entrances. The gradient of the ramp to be maintained at 1:12.
- ❖ Hand rails must have the Braille indicators.
- ❖ Ramps shall be signposted as per standards.

# **APPROACH TO BLOCKS / PATHWAYS**

## **Walkways / pathways**

- ❖ Provision of continuous accessible pathways for PWD's throughout the site by implementing the following points:
- ❖ Identification of a continuous route starting from the entrance and interconnecting all the important buildings in the site.
- ❖ Providing ramps at all level differences along this route.
- ❖ Providing tactile guiding path along the route for Pwd' s.
- ❖ All pathways should be firm and slip-resistant.
- ❖ Discontinuous, damaged and unfinished pathways to be repaired, continued and finished.
- ❖ Vegetation growing on the pathways to be removed and the pathways to be maintained.
- ❖ Junctions between pathways to be smoothed and made seamless.
- ❖ Kerbs to be provided around all the green spaces/ flower beds/ plantations.
- ❖ If a pathway leads to a spatial change or a change in level, directional cues such as signage, kerbs, handrails, fences, hedges, or other continuous elements etc. should be provided at strategic locations to maintain travel continuity for the user. This is particularly important for visually impaired users to continue along the travel path to reach their destination.
- ❖ Kerb ramps with tactile warning and color contrast to be provided to bridge level differences less than 150mm along pathways.
- ❖ Edges of pathways should be clearly defined by using different colors / textures. Street furniture, trees, lighting and dustbins should be located on one side of pathways.
- ❖ Texture, color and pattern of the change in floor surfaces, as well as the lighting effect on the floor surface, should not be too sudden as to cause hazard or discomfort to users.



## EXTERNAL ENVIRONMENT - PARKING

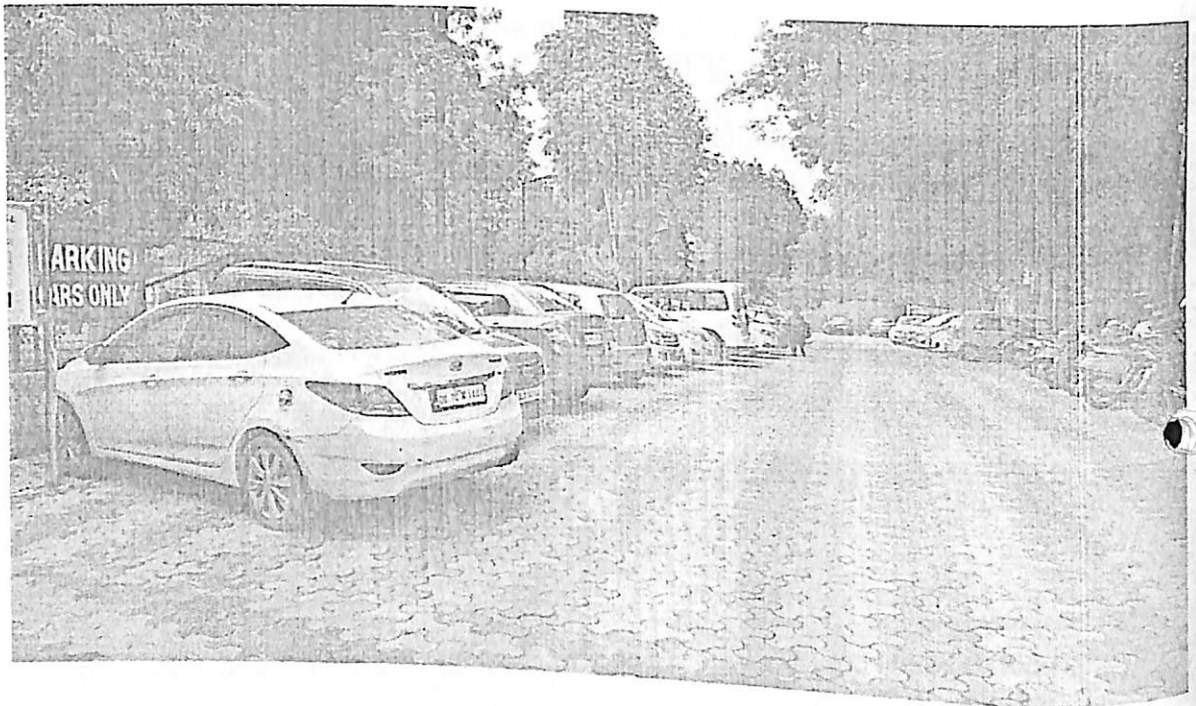

### Observations and Suggestions:

- ❖ There are no signages of Parking for two wheelers, four wheelers in accessible formats.
- ❖ There is no reserved parking for disabled people.
- ❖ Consider providing at least three Reserved parking properly sign posted. The size of the reserved parking shall be a min of 3600 mm by 5000 mm.
- ❖ In general parking standards are provided in the following page and they may be referred while retrofitting / redesigning of parking areas.
- ❖ Surfaces are even. Consider installing the tactile tiles as per specifications described in the standards from the parking bay to the principal point of entry.
- ❖ Provision for the tactile path shall be made from the parking lot and shall be connected to the ones leading to the access route.
- ❖ All the entry exit points shall be connected through the tactile path. Displaying all the features of all the facilities on the Tactile Audio Layout / Tactile Layout is mandatory.
- ❖ Consider providing a shed for parking.

## **PARKING**

- ❖ The parking near the entrance gate to be demarcated and a separate accessible pedestrian pathways to be created leading to the entrance gate.
- ❖ At least 2 accessible parking bays to be provided.
- ❖ 1 accessible parking bay to be provided at the entrance and another one to be provided in near any of the centrally placed buildings.
- ❖ Accessible parking space should be located nearest to the entrance gate or adjoining an accessible pedestrian route that leads directly to one of the main entrances of a facility.
- ❖ Accessible parking bays should be provided and laid out within 30m to the principal public entry point to the site.
- ❖ There should be clear information accessible to all, discouraging the misuse of accessible parking bays.
- ❖ Each accessible parking bay should be of dimension (3600 x 5000 mm) including alighting space of 1200mm and should be clearly demarcated on floor and signposted.
- ❖ Signpost of international symbol of accessible parking should be provided at 2100mm height and of 600mm x600mm size for easy visibility from driver's seat.
- ❖ The parking bays should have firm and leveled surface.
- ❖ Accessible parking bays should have side and rear transfer zones for removal and set up of a wheelchair from the boot of a vehicle or for use of a rear-, or side-, mounted wheelchair hoist.
- ❖ Parking area should be well lit and, where practicable, covered.
- ❖ There should be well defined step free and barrier free route with a tactile guiding path to the main accessible entrance from the parking bays.
- ❖ Trees in parking to be provided with a grating cover and guardrails as shown in the detail on standards page.
- ❖ Accessible directional, multilingual and tactile signage to be provided as per standards on the floor and on the wall / post.
- ❖ All security guides / guards should be sensitized and well informed about reserved parking for PWDs.

## INTERNAL ENVIRONMENT – SERVICE DESKS / COUNTERS

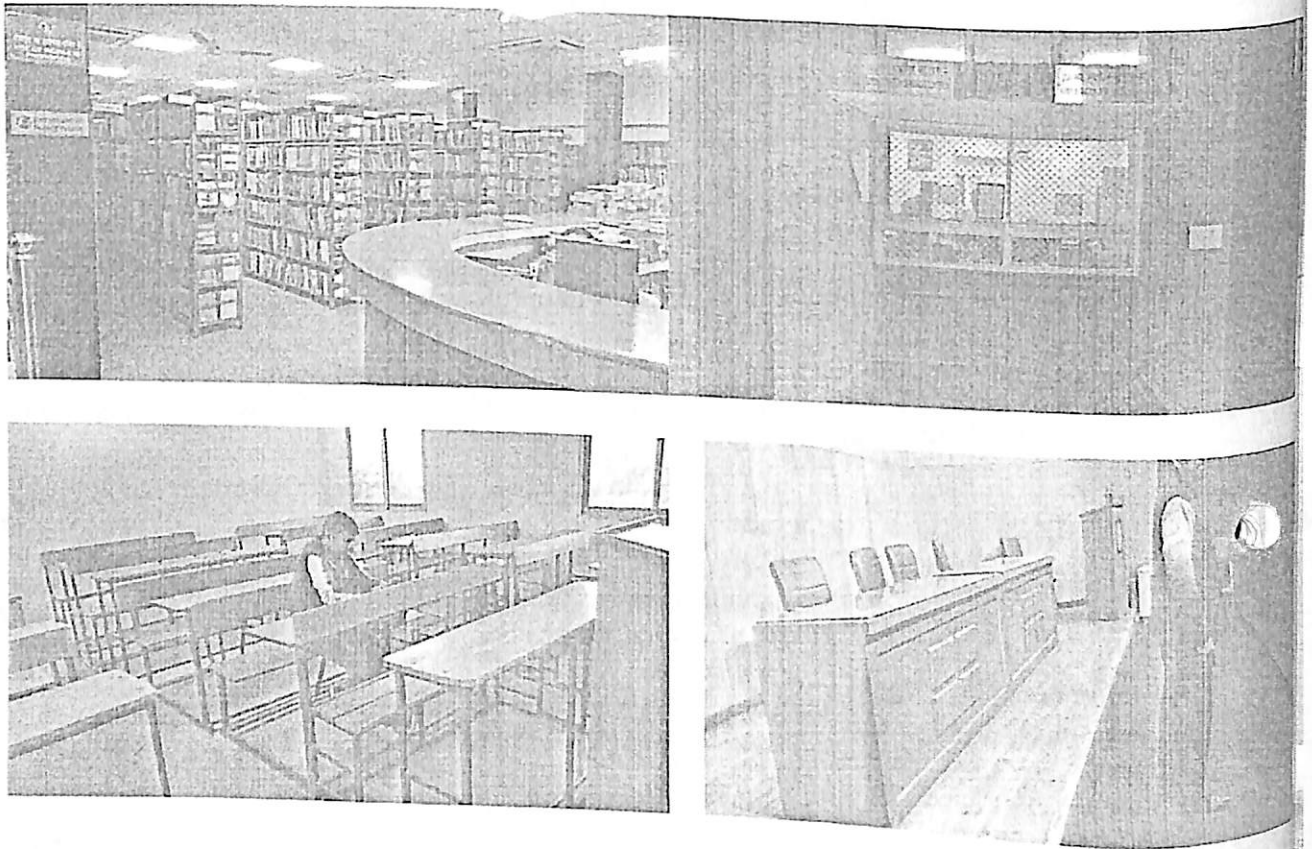

### Observations and Suggestions:

- ❖ The Library Desk / registration Counters and seating areas are inaccessible to persons with disabilities.
- ❖ Every service desk must be accessible to people with disabilities.
- ❖ Waiting area should be provided and a guidance path and an accessible route must be created.
- ❖ Signages must be provided as per standards.
- ❖ Tactile Tiles used for navigation of blind people are missing and they must be provided to create an accessible path.
- ❖ A disability desk may be provided as it shall serve as a better accessible space for various activities in the Library.
- ❖ A tactile layout of the premises may be provided such that it shall be easy for people to navigate.
- ❖ The Dias at the auditorium is inaccessible too and a ramp (temporary shall be created.)



## INTERNAL ENVIRONMENT – SERVICE DESKS / COUNTERS

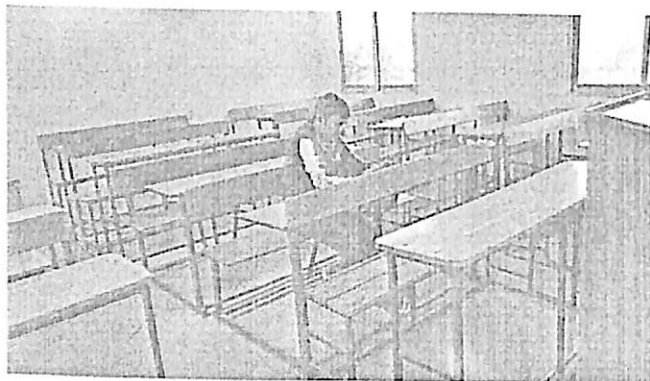
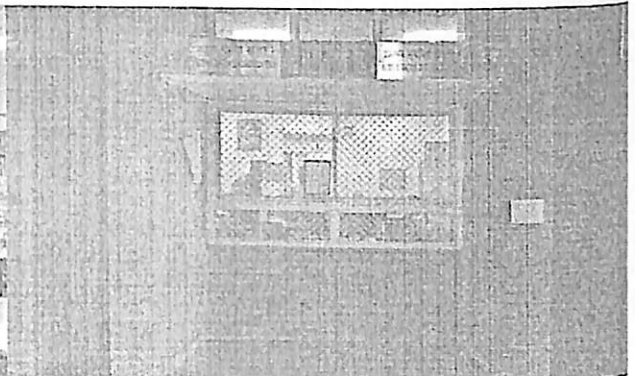
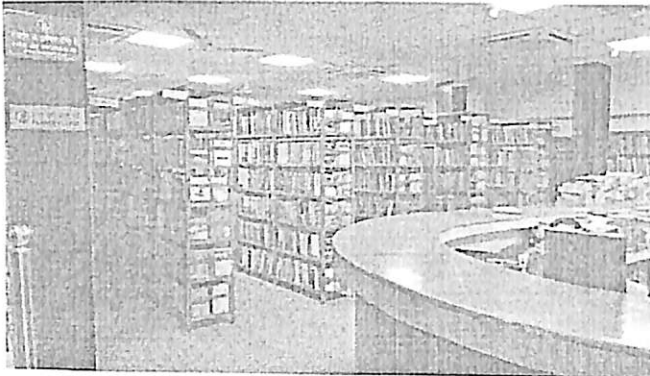

### Observations and Suggestions:

- ❖ The Library Desk / registration Counters and seating areas are inaccessible to persons with disabilities.
- ❖ Every service desk must be accessible to people with disabilities.
- ❖ Waiting area should be provided and a guidance path and an accessible route must be created.
- ❖ Signages must be provided as per standards.
- ❖ Tactile Tiles used for navigation of blind people are missing and they must be provided to create an accessible path.
- ❖ A disability desk may be provided as it shall serve as a better accessible space for various activities in the Library.
- ❖ A tactile layout of the premises may be provided such that it shall be easy for people to navigate.
- ❖ The Dias at the auditorium is inaccessible too and a ramp (temporary shall be created.)

# INTERNAL ENVIRONMENT - CORRIDORS

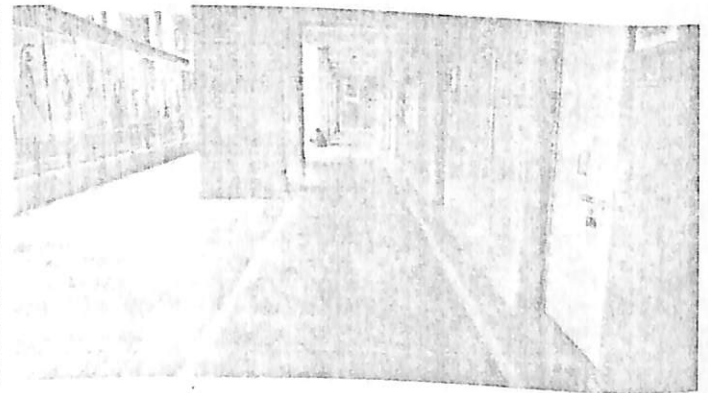
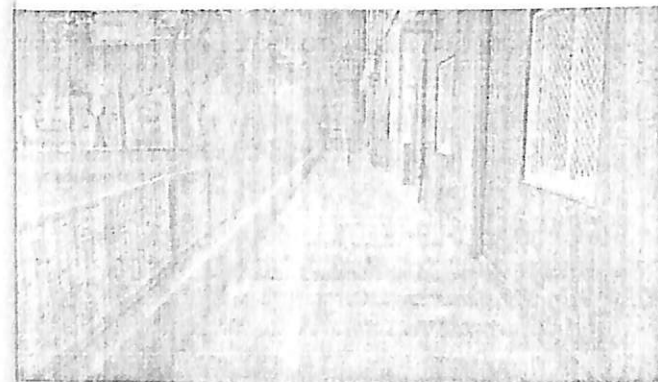
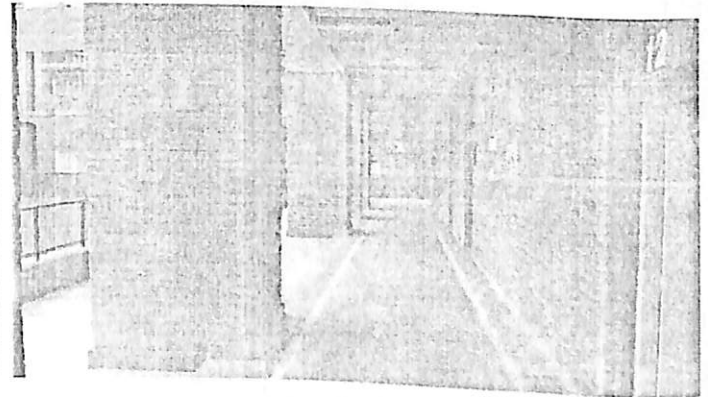
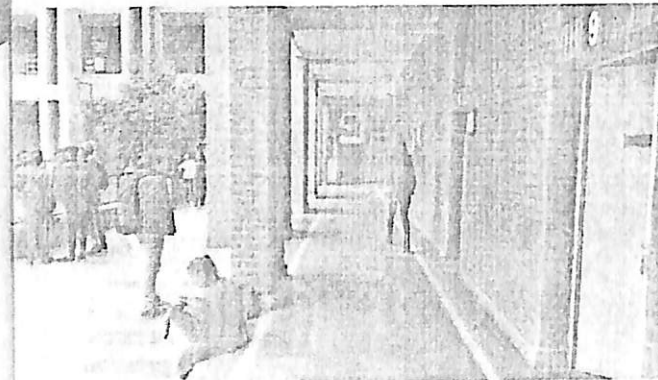
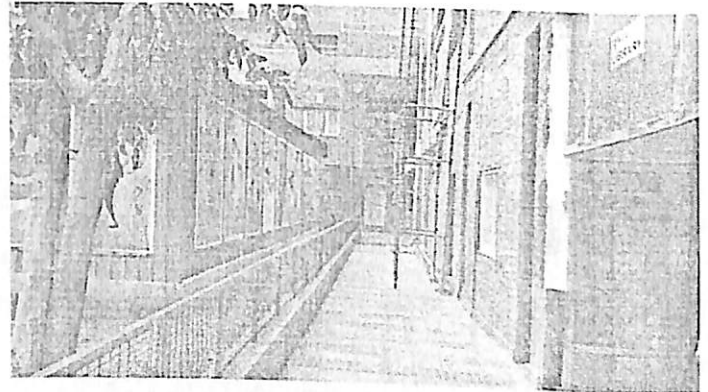
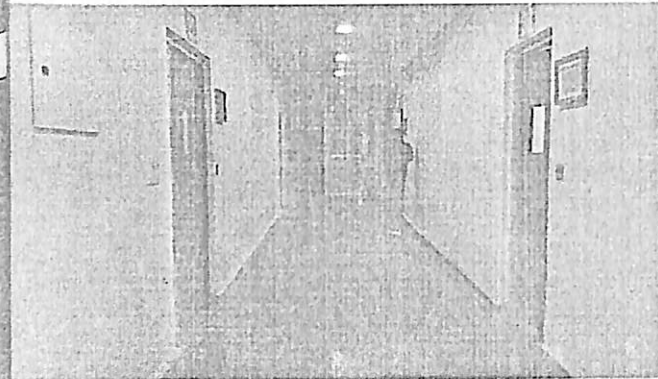
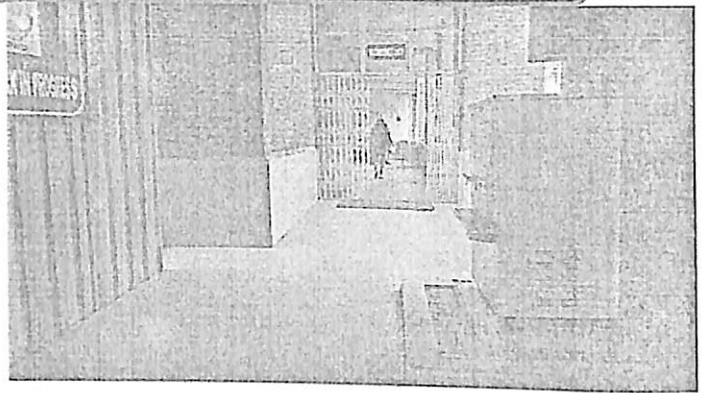
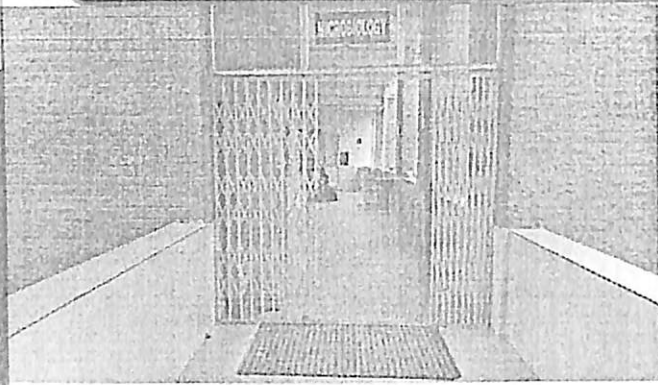

## INTERNAL ENVIRONMENT - CORRIDORS

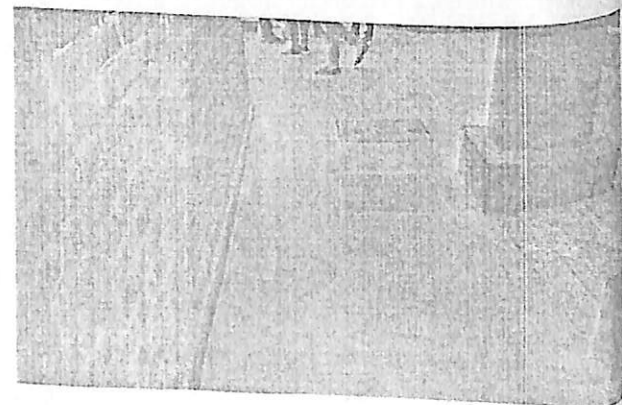
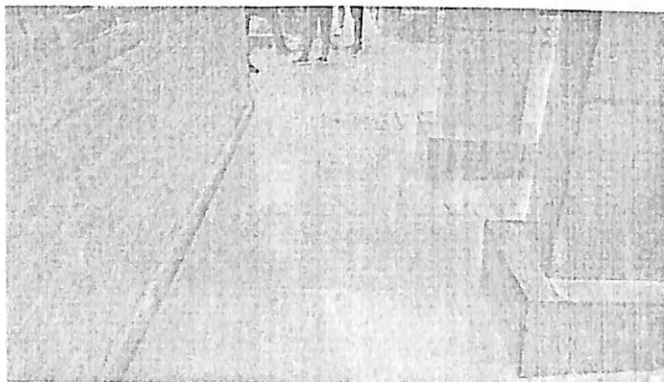
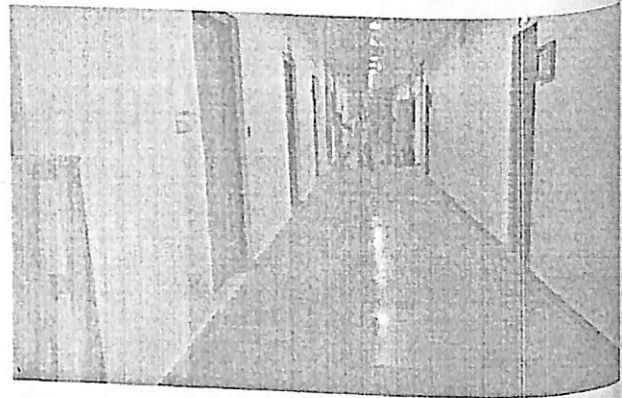
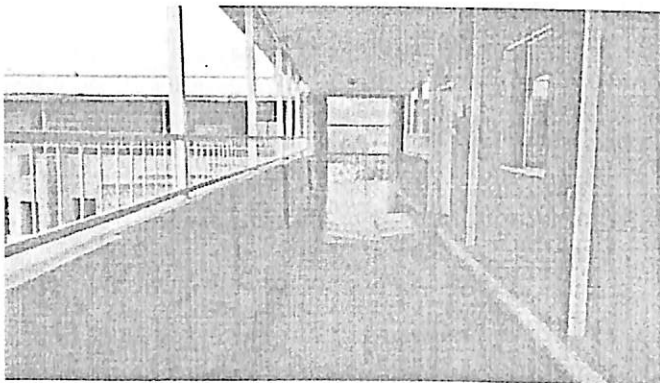
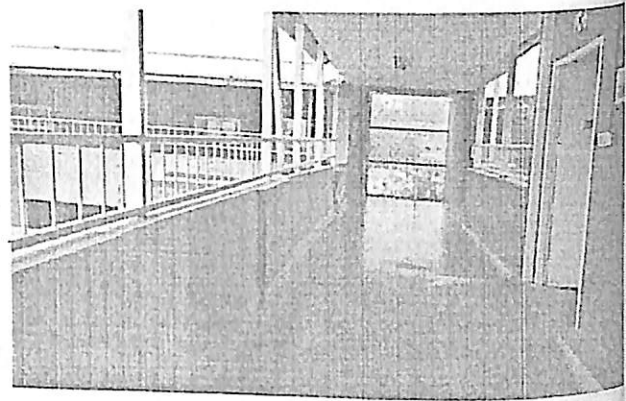
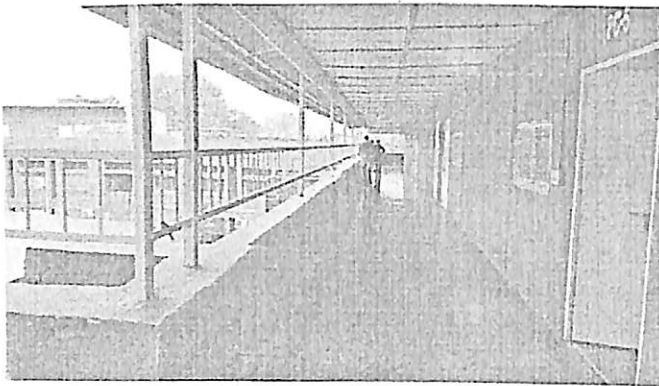

### Observations and Suggestions:

- ❖ Directional, positional, Warning tiles used by people with blindness and low vision are missing and may be provided.
- ❖ Floor Directories must be designed keeping in mind suggestions provided in the standards page covering all exits, toilet facilities, elevators, stairs, etc.
- ❖ The Informational / Identification / Evacuation Signages are missing and may be provided.
- ❖ Fire evacuation lay outs must be provided at appropriate places
- ❖ Consider providing the Fire Extinguishers at a height of 700 mm.
- ❖ Railing is not found as per standards in corridors which is to be implemented.
- ❖ The Corridor must be free from Obstacles. Waiting and resting space be clearly be sign posted.



## INTERNAL ENVIRONMENT - DOORS

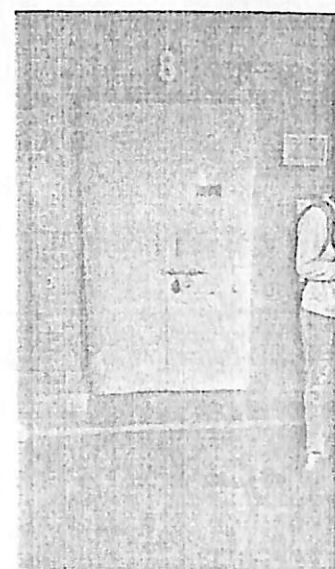
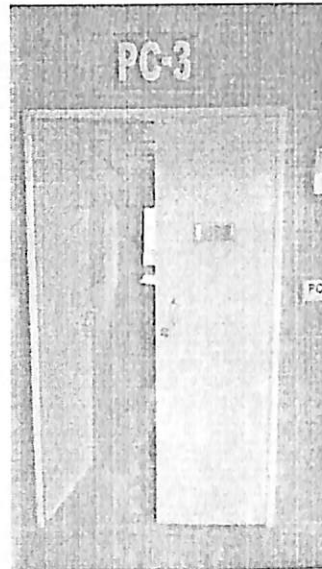
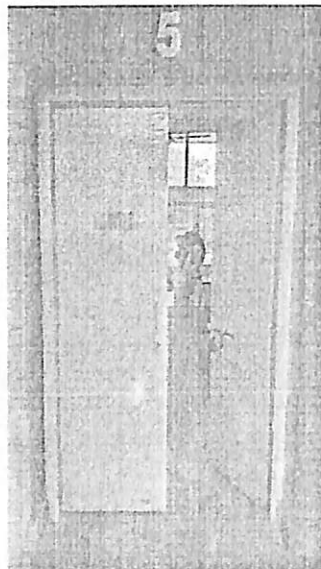
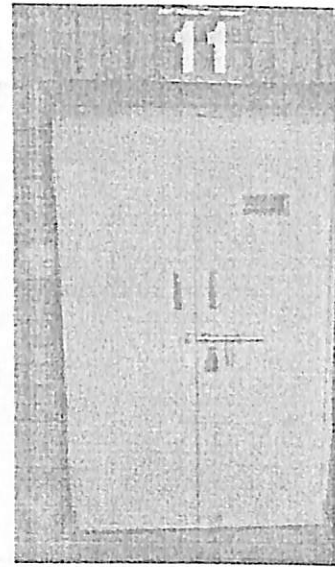
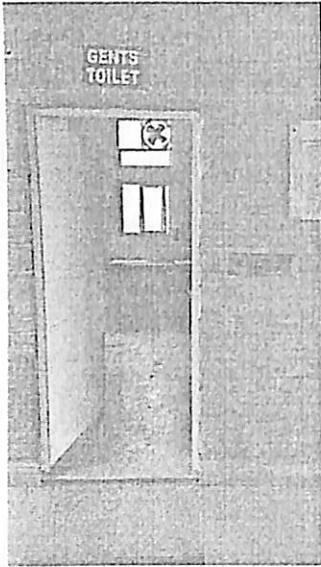

### Observations and Suggestions:

- ❖ The width of the doors are found to be as per guidelines on most entrances except a few internal doors such as toilet doors or doors at facilities.
- ❖ The Min clear space for all the doors is 900 mm.
- ❖ Consider providing push bars on doors wherever possible and ensure that there are no level differences.
- ❖ Consider no obstacles such as mats are obstructing the opening and closing of the doors.
- ❖ In case of wooden doors provide a wide see through it helps while opening and closing of doors ( Entrance Doors / Doors in Corridors / Lobby Area / Common Area).
- ❖ All Signages on the Doors shall be in Braille and as per signage specs provided in the guidelines below.
- ❖ Consider Ramps / slopes and railings as per the standards wherever there are stepped Entries.

## INTERNAL ENVIRONMENT - STAIRS

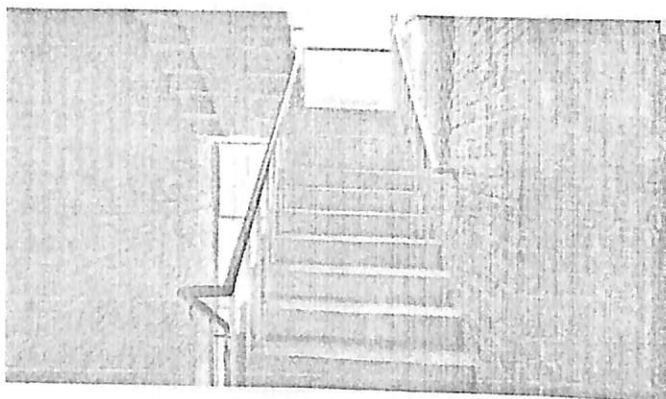
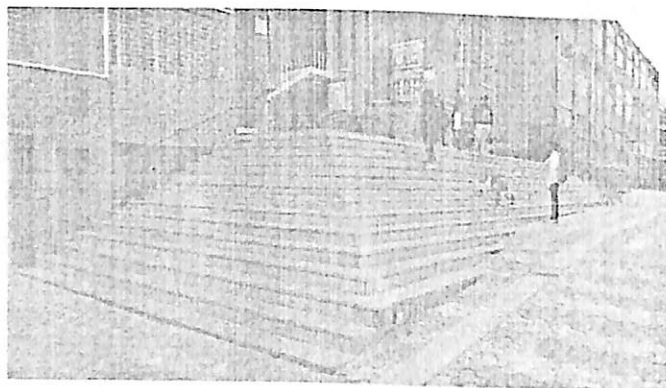
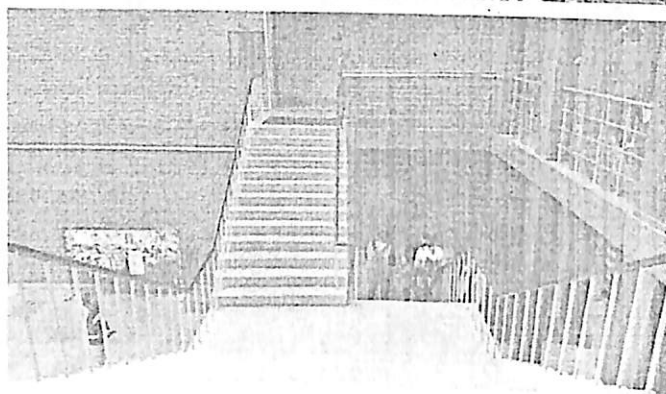
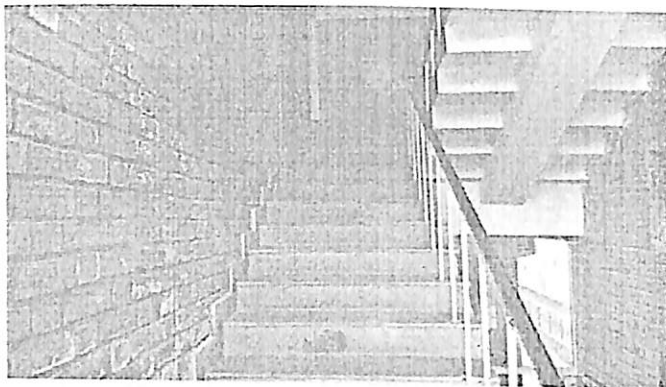

### Observations and Suggestions:

- ❖ Tactile warning tiles are must before the Stairs Start.
- ❖ There are Railings on both sides of staircase which is good practice
- ❖ Consider installing yellow colored tape for making the stairs identifiable in low lighting conditions.
- ❖ Positional and guiding tiles may be installed appropriately
- ❖ Please consider installing anti skid tape 25 - 30 mm on the stairs as described in standards.
- ❖ Signages indicating staircase are to be provides.
- ❖ Provision of Braille Signages on Railings and start of the Steps is mandatory.
- ❖ Ramps must be provided where they lead to an entrance.
- ❖ Provision of Anti Skid Tapes on the treads of the stair case.
- ❖ Evacuation and Emergency mandatory in braille must be provided.
- ❖ The risers and steps width and height as are per specifications and are acceptable.

## INTERNAL ENVIRONMENT – DRINKING WATER FACILITIES

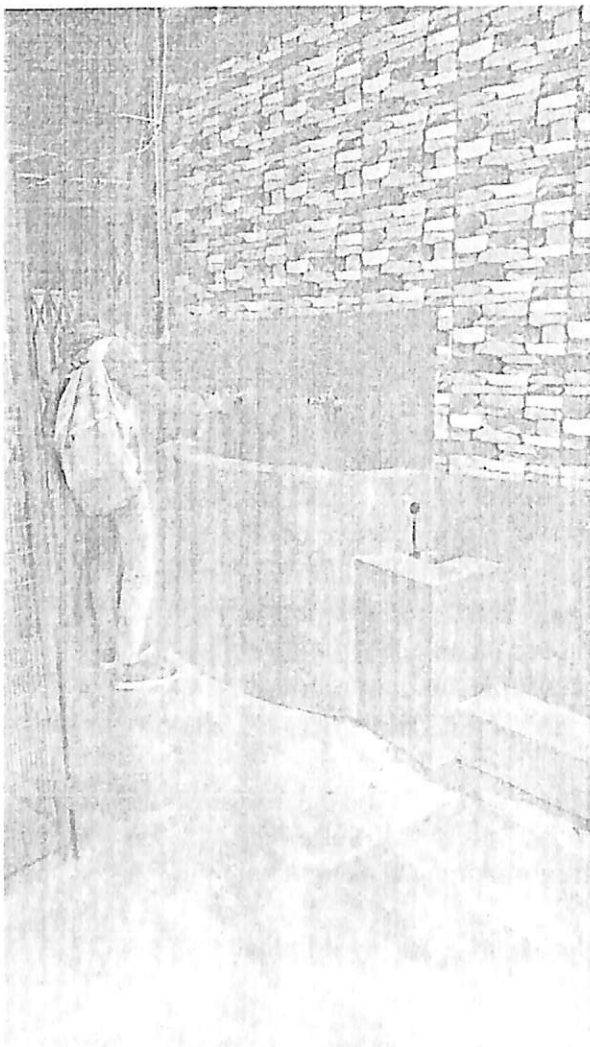
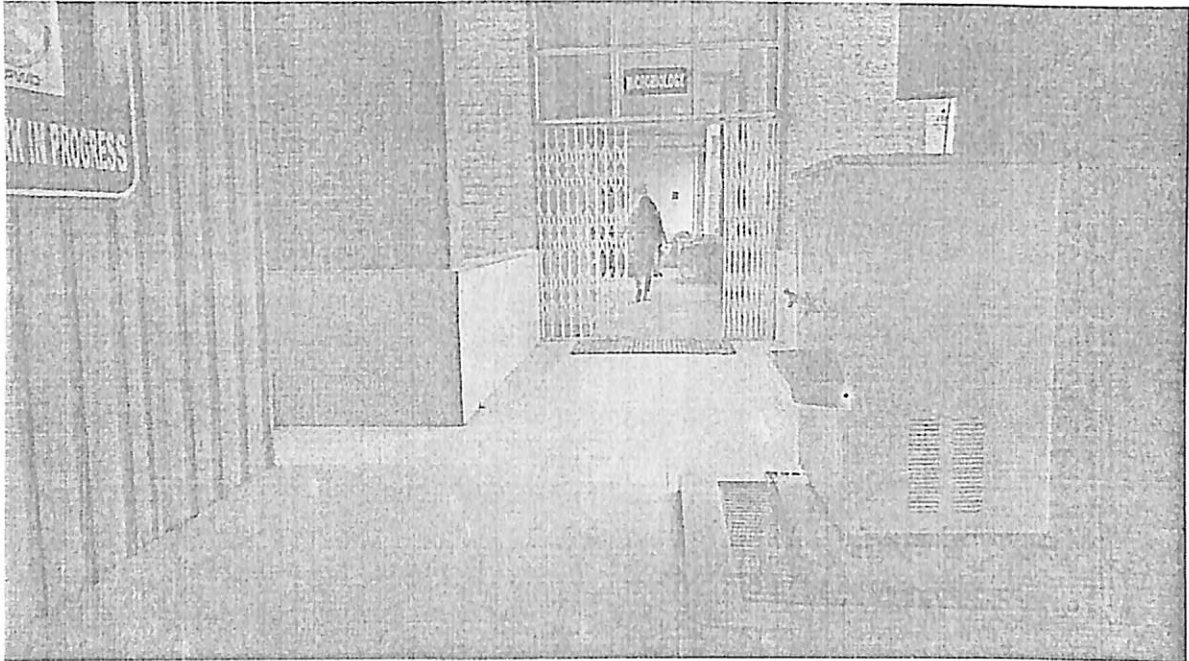

### Observations and Suggestions:

- ❖ Drinking water facilities are available at the campus.
- ❖ The maintenance around the facilities is poor.
- ❖ The Signages were missing.
- ❖ There was no provision of disposable or usable glasses near the facility.
- ❖ The height of the Drinking water facilities were not as per the standards at one of the locations.
- ❖ Level Difference was found at these facilities.
- ❖ No tactile path was routed to the facility.
- ❖ Maintaining the Facilities is of utmost importance.

## INTERNAL ENVIRONMENT TOILET FACILITIES

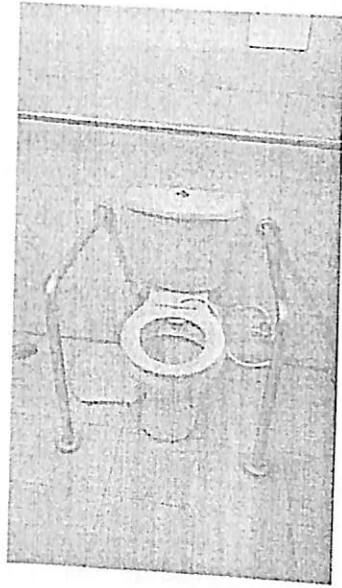

### KEY ISSUES

- ❖ An accessible toilet cubicle has not been provided in the toilet blocks.
- ❖ The internal configuration of the accessible toilet (location of WC, location grab bars, circulation space for a wheelchair etc.) is to be maintained as per standards, It is advisable to have a new toilet block constructed as trying to accommodate the Accessible toilet shall disturb the configuration of the existing toilets.
- ❖ There are level differences at door openings. The Toilets are poorly maintained.
- ❖ The Width of the door is less than 900 mm making it inaccessible.
- ❖ At least one Block on the ground floor / each floor be provided with an Accessible toilet in each Residential Block.



## RECOMMENDATIONS

- ♦ Low heighted/ accessible wash basins, urinals, mirrors to be provided in each toilet block for a low heighted person, wheelchair user.
- ♦ Level differences to be sloped.
- ♦ The accessible toilet cubicles to be improvised/ reconfigured as per the following standards.
- ♦ A full range of user-friendly provisions should be made to reach the toilet blocks including tactile guide path, floor plan with illustrations in written text and Braille, and large information signs.
- ♦ Accessible toilets should have the universally adopted symbol for wheelchair access displayed outside.
- ♦ Location of general / accessible toilets to be marked on all tactile pictographic maps.
- ♦ Recommended clear floor space for accessible toilet is -2000mmx 2200mm minimum.
- ♦ Where provision of independent unisex accessible toilet blocks is not feasible, Accessible toilet cubicles should be provided within the existing ladies and gent's toilets by reconfiguring internal layout to achieve an ideal size of 2000mm x 2200mm. (Without compromising on other requirements too.
- ♦ Drinking water fountains of two mounting heights should be provided and preferably located near the toilet blocks but away from the toilet entrances.
- ♦ A step free, levelled tactile guiding path to be provided in the floor from corridors / walkways leading to the accessible toilet blocks.
- ♦ The main entrance door / opening to the toilet and internal cubicles should be minimum 900mm in width.
- ♦ There should be no level differences inside all toilet blocks. Existing level differences to be removed or beveled to facilitate easy wheelchair movement.
- ♦ Facilities should have wide and level layouts with good colour contrasts providing enough space for wheelchairs and other mobility aids.
- ♦ There should be signage using the international symbol of accessibility to identify the accessible toilets. Signage should be multi lingual and tactile.



INTERNAL ENVIRONMENT INTERNAL SIGNAGES

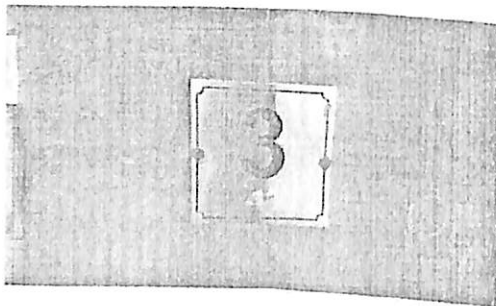
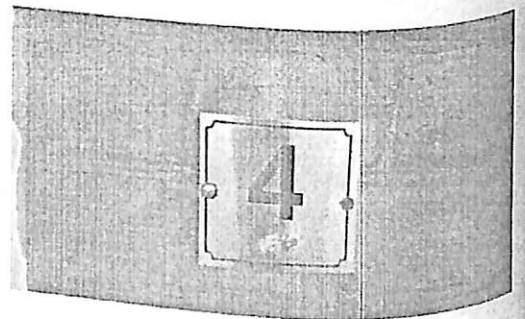
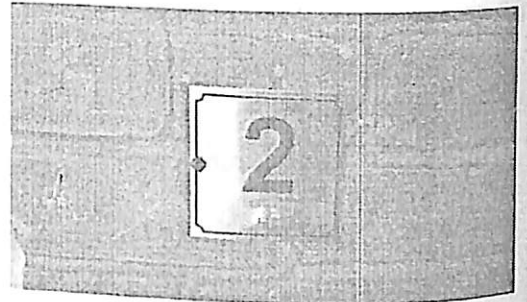
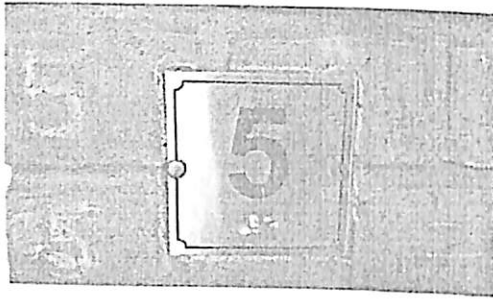





## **INTERNAL ENVIRONMENT - SIGNAGES**













### **Observations and Suggestions:**

- ❖ There are a few signages provided internally and external , however none of the signages are as per standards.
- ❖ No Accessible Universal Signages were seen in the premises.
- ❖ Most of them were SS based and are against the guidelines issued by CPWD / MOUD Govt. Of India.
- ❖ There were few Directional / Informational Signages.
- ❖ Emergency Evacuation layouts, Audio Tactile Pictorial building maps are not found at all.
- ❖ All rooms must be provided with Braille Signages that are also audio compensated.
- ❖ All common signages must be as per the guidelines strictly.

## ACCESSIBILITY EVALUATION

Evaluation Rank	Evaluation Criteria	Symbol	Priority for creating access
1	Hazardous, Inaccessible and Unsatisfactory		Highest
2	Inaccessible and unsatisfactory		High
3	Unsatisfactory but acceptable		Moderate
4	Accessible and Acceptable - Access Code Compliant		Low
5	Accepted as a Best Practice in Accessibility		Lowest

## ACCESSIBILITY EVALUATION AS PER STANDARDS.

Accessibility	Area	Ranking	Priority for creating access
1	Parking		Highest
2	ALIGHTING		Highest
3	ACCESSIBLE ROUTE		highest
4	ACCESSIBLE ENTRANCE		Moderate
5	RECEPTION & LOBBY		Moderate
6	RAMP		Moderate
7	CORRIDORS		Moderate
8	DOORS & DOORWAYS		Moderate
9	ACCESSIBLE TOILET		Highest
10	DRINKING WATER FACILITY		Moderate
11	SIGNAGE		Highest
12	EMERGENCY EVACUATION		Highest



# ACCESSIBLE PARKING STANDARDS

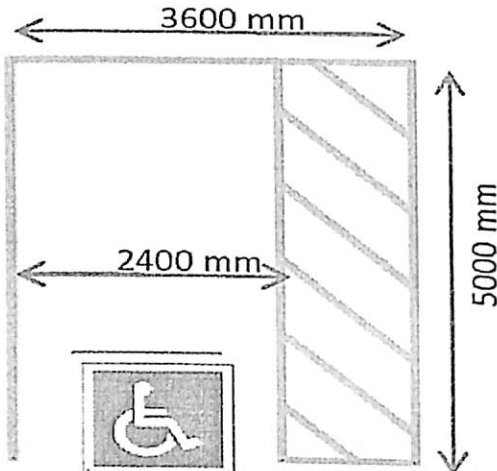

ACCESSIBLE PARKING BAY AND ALIGHTING AREA

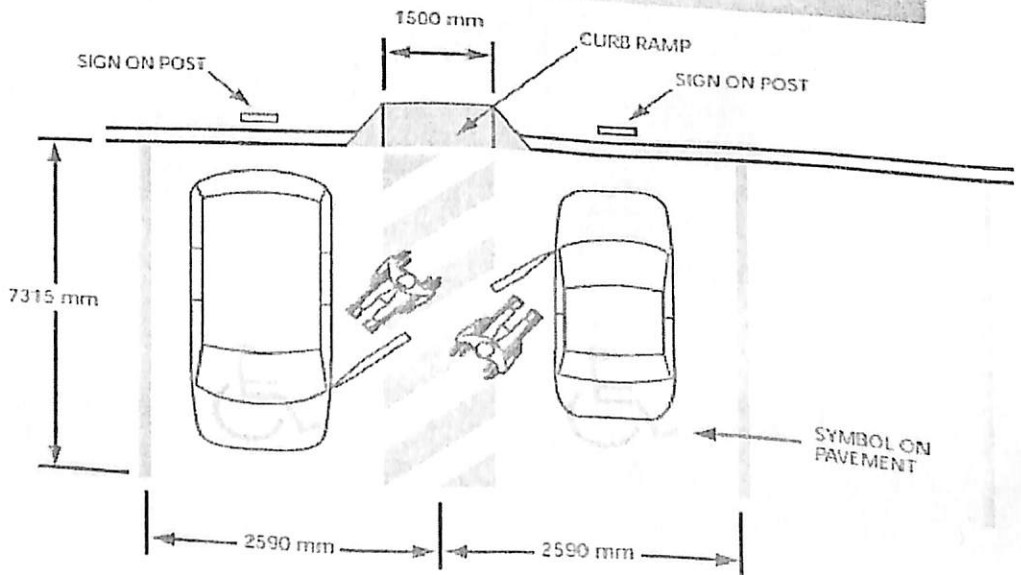
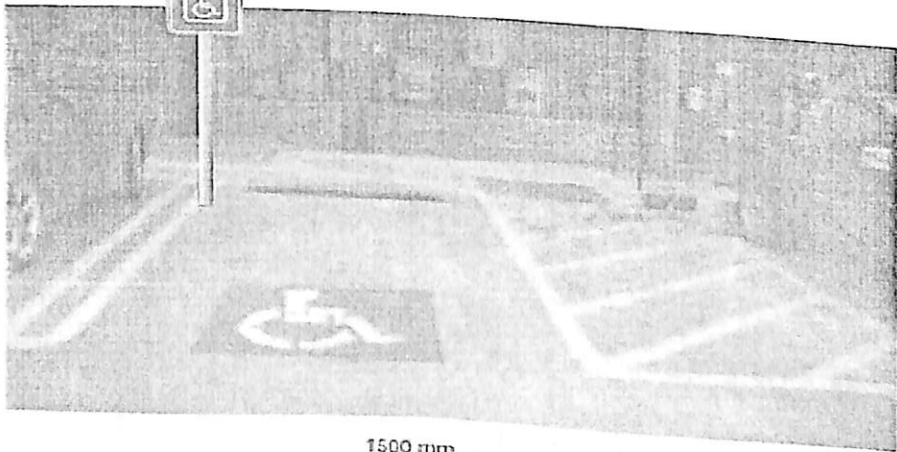
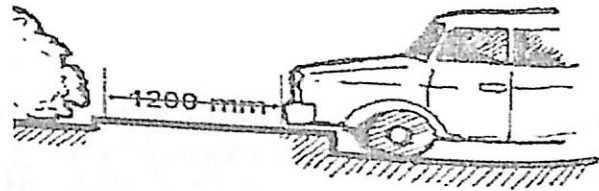
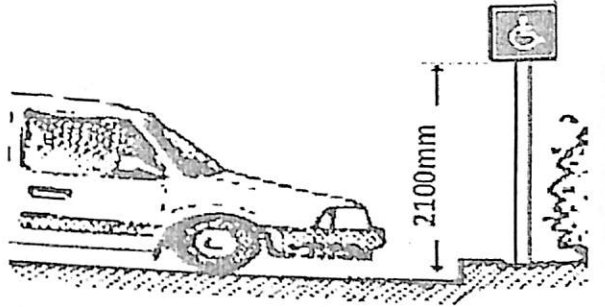

These are suggested ranges the minimum shall be 3.6 Mtr by 5.0 mtr





## TACTILE TILES & WASTE BINS

- ❖ Directional, location and hazard warning tactile surfaces should be correctly laid to convey correct information.
- ❖ Following two types of tactile guiding surface indicator (TGSi) should be provided to guide and alert PwVI.
- ❖ Directional tile: It consists of raised parallel bars to guide people along the direction of a tactile path.
- ❖ Warning tile: It consists of raised truncated domes arranged in square grid parallel to the sides of the tile to alert people of potential hazards such as top and bottom of stairs, door openings and at pedestrian crossings.

### Places to install tactile tiles:

- ❖ In front of an area where traffic is present.
- ❖ In front of an entrance / exit.
- ❖ To and from a staircase or multi-level crossing facility.
- ❖ In open space to orient PwVI.
- ❖ Tactile warning tiles should be provided where there is a change in levels, e.g., at top and bottom of stairways and ramps.
- ❖ Tactile surfaces should be laid at a distance from wall surfaces to facilitate left handed or right handed persons with guiding sticks.
- ❖ Tactile surfaces should preferably be apart from pathways for wheelchair users to avoid conflict between the two user groups.
- ❖ Avoid any door swings into the tactile surfaces.

### Waste bins

- ❖ Waste bins should be provided at strategic locations and at max. 30m distance in between.
- ❖ Waste bins should be accessible to all users and be permanently located to one side of any path or walkway so as not to encroach on walkway width.

Waste receptacles should be securely mounted on firm level pads.

Waste bins should be clearly identified by suitable signs and colours.

Where lids are provided on waste receptacles, they should be easy to operate with one hand and have big openings mounted no higher than 1065 mm from grade.

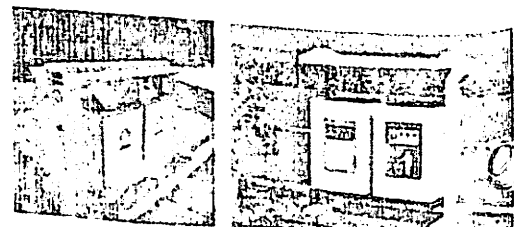
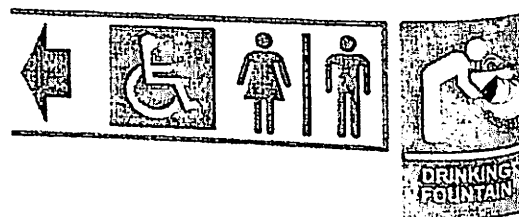

RECOMMENDED WASTE BINS



# TACTILE TILES & GRATINGS, CIRCUMVENTING TREES & POLES

Guiding path and approaching sidewalk to the building

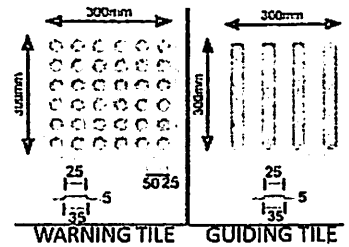
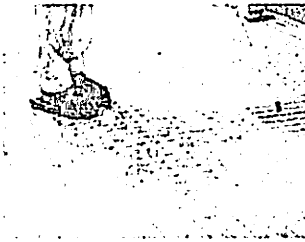
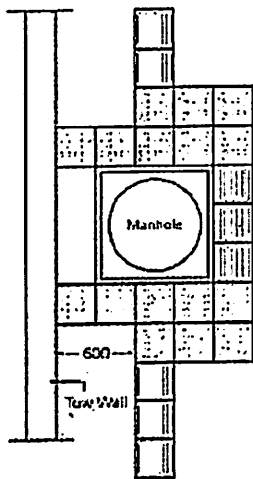
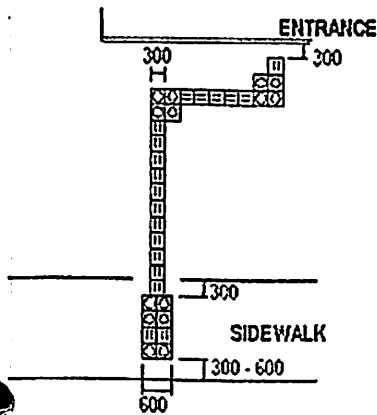

Arrangement of guiding blocks for persons with visual impairment

EXAMPLE OF INTERSECTION



EXAMPLE OF L-SHAPED INTERSECTION



EXAMPLE OF T-SHAPED INTERSECTION

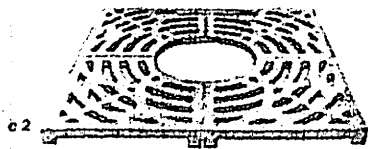

Specification  
 1. Iron Tree Surround consists of 4 Noe panels of 750mm x 750mm of 4mm/10mm Thickness or 600mm x 600mm of 40/100mm Thickness  
 2. Overall dimensions 1500mm x 1500mm x 40/100mm (Thickness) or 600mm x 600mm x 40/100mm Thickness  
 3. Suitably reinforced for long use and to prevent damage during transportation & handling.

COMMENDED BRAND FOR GRATING  
 Manhole & Gratings Co.(P) Ltd.  
 New Delhi

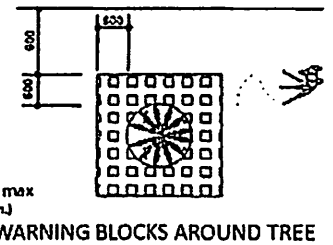
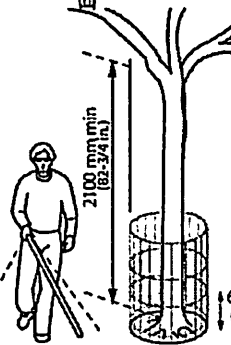
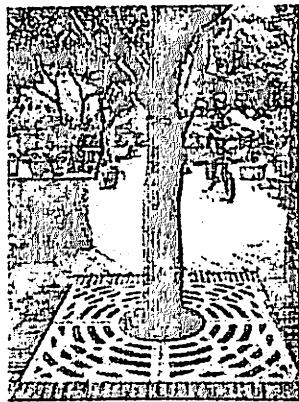

Provision of continuous accessible pathways for PWD's throughout the site by implementing the following points:

Identification of a continuous route starting from the entrance and interconnecting all the important buildings in the site.

Providing ramps at all level differences along this route.

Providing tactile guiding path along the route for PwDs. All pathways should be firm and slip-resistant.

Discontinuous, damaged and unfinished pathways to be repaired, continued and finished.

Vegetation growing on the pathways to be removed and the pathways to be maintained.

Junctions between pathways to be smoothed and made seamless.

Kerbs to be provided around all the green spaces/ flower beds/ plantations.

If a pathway leads to a spatial change or a change in level, directional cues such as signage, kerbs, handrails, fences, hedges, or other continuous elements etc. should be provided at strategic locations to maintain travel continuity for the user.

This is particularly important for visually impaired users to continue along the travel path to reach their destination. Kerb ramps with tactile warning and color contrast to be provided to bridge level differences less than 150mm along pathways.

Edges of pathways should be clearly defined by using different colours / textures. Street furniture, trees, lighting and dustbins should be located on one side of pathways.

Texture, color and pattern of the change in floor surfaces, as well as the lighting effect on the floor surface, should not be too sudden as to cause hazard or discomfort to users. Junction between the different floor surfaces should be levelled. any gaps or expansion joints between different materials should not exceed 13mm wide.

## TACTILE TILES

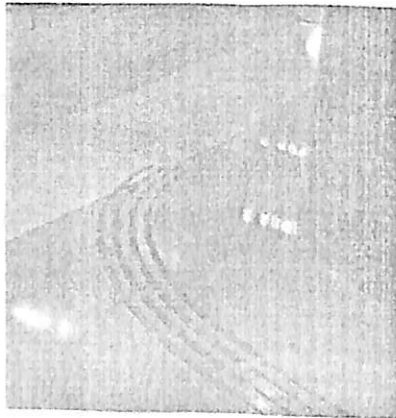
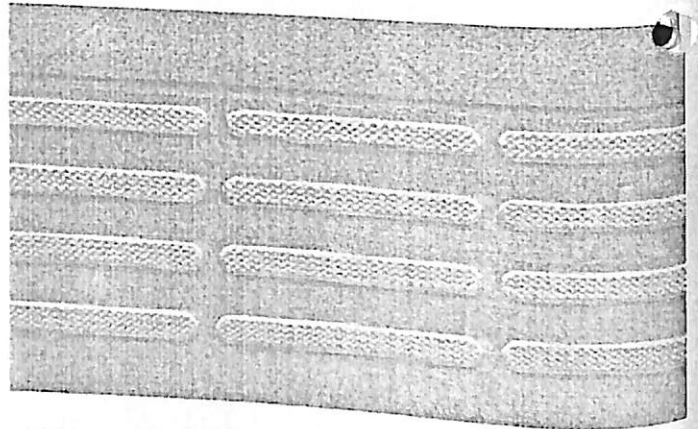
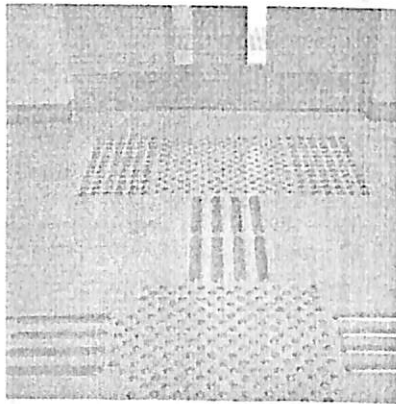
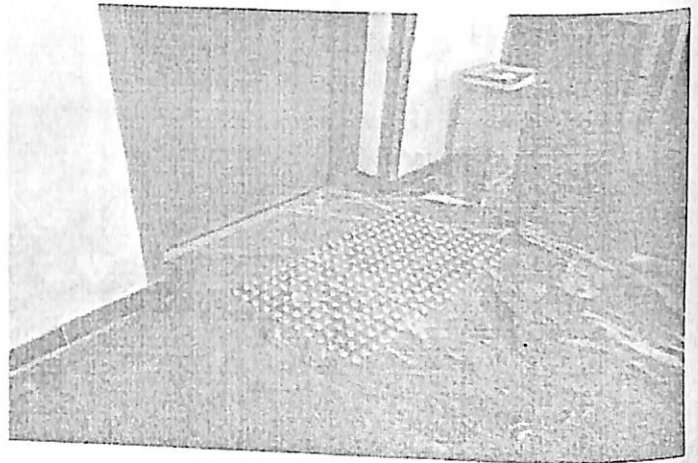
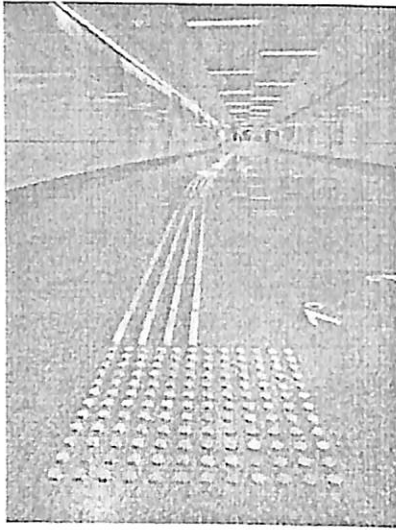

EXAMPLES METAL WARNING STUDS AND DIRECTIONAL STRIPS FOR EXTERIORS AND INTERIORS

Cement Tiles for External (entrance to the Main Building, Ceramic Tiles For Internal Tiles, or S S Stud and Strips be used for tactile flooring.

## INTERNAL ENVIRONMENT

- ❖ The existing reception / service counters to be modified as shown such that a part of the counter is between 760 mm to 800mm from the floor with a 400mm to 600mm clear recess under the counter
- ❖ Accessible directional, multilingual and tactile signage to be provided as per standards
- ❖ Provide tactile guiding path in the floor leading to the reception / ticket counters
- ❖ Provide a tactile pictographic map of the building near the counter
- ❖ Reserved waiting spaces for wheel chair users to be demarcated (750 x 1200mm)
- ❖ Provide tactile guiding path in the floor for navigating through the waiting lounge independently for PwVI
- ❖ Accessible directional , multilingual, braille and tactile signage to be provided as per standards
- ❖ Door manifestations should be of contrast colour as shown in the detail in section on Doors
- ❖ Warning tiles and/or guard rails to be provided around free standing pillars

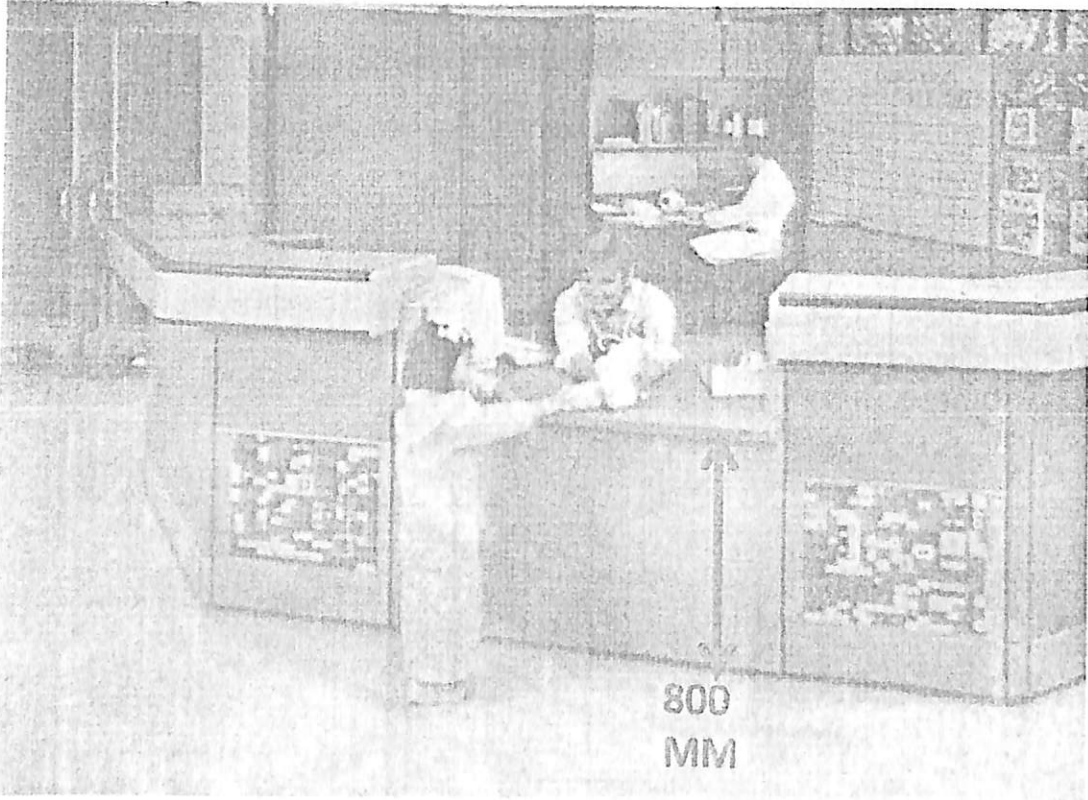

EXAMPLE OF AN ACCESSIBLE SERVICE COUNTERS

# INTERNAL ENVIRONMENT

## RECEPTION / SERVICE COUNTERS AND WAITING

- ❖ The existing reception / service counters to be modified as shown such that a part of the counter is between 760 mm to 800mm from the floor with a 400mm to 600mm clear recess under the counter
- ❖ Accessible directional, multilingual and tactile signage to be provided as per standards
- ❖ Provide tactile guiding path in the floor leading to the reception / ticket counters
- ❖ Provide a tactile pictographic map of the building near the counter
- ❖ Reserved waiting spaces for wheel chair users to be demarcated (750 x 1200mm)
- ❖ Provide tactile guiding path in the floor for navigating through the waiting lounge independently for PwVI
- ❖ Accessible directional , multilingual, braille and tactile signage to be provided as per standards
- ❖ Door manifestations should be of contrast colour as shown in the detail in section on Doors
- ❖ Warning tiles and/or guard rails to be provided around free standing pillars

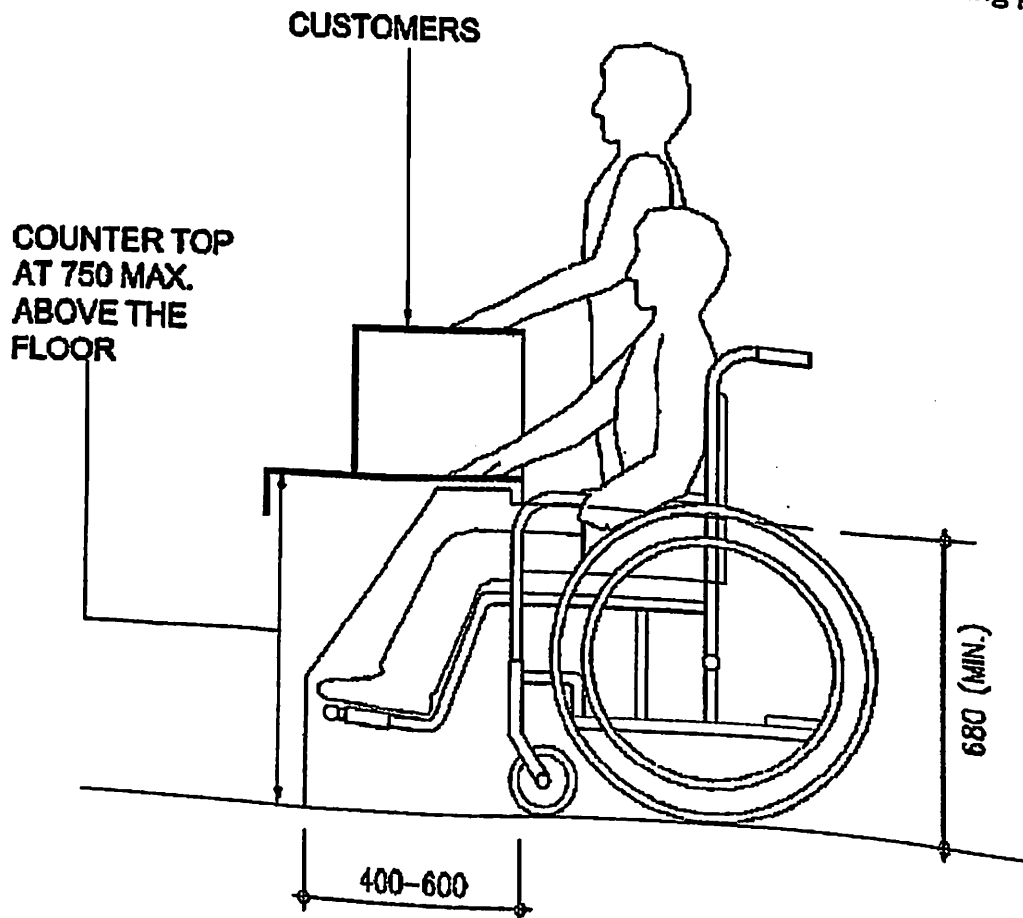

# STAIRS / MARKINGS / CONTRAST TAPES

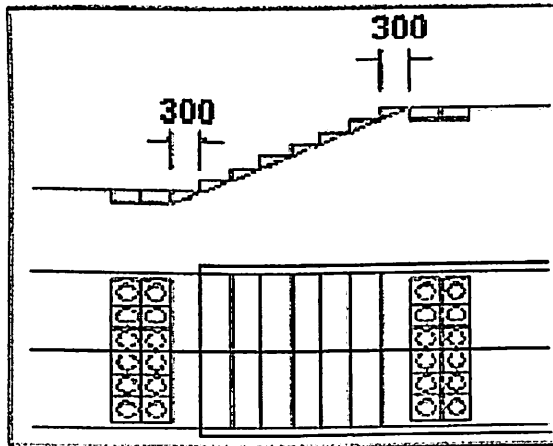

WARNING TILES LOCATION

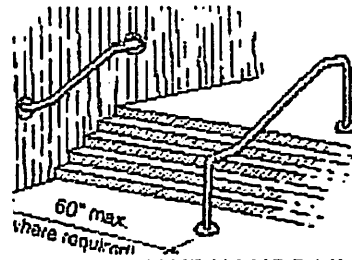

INTERMEDIATE HANDRAIL

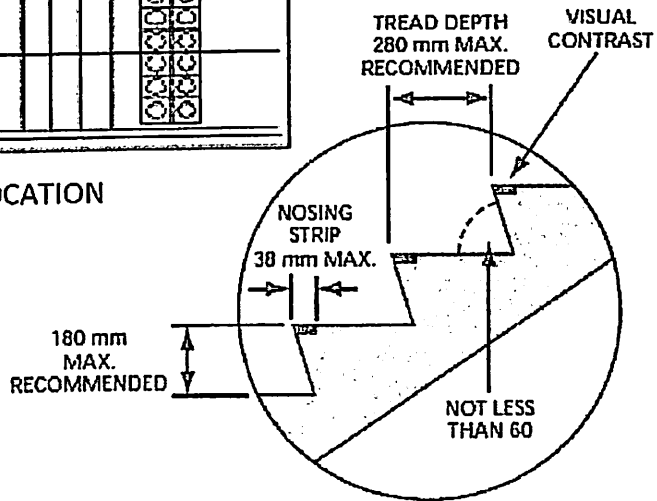

WARNING TILES AND EDGE STRIPS

CONTRAST COLOUR EDGE STRIPS DETAIL

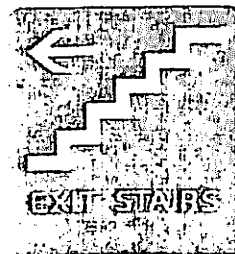
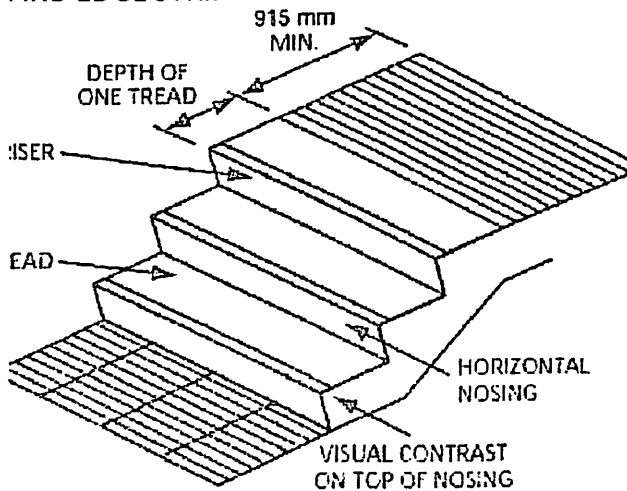

SIGNAGE

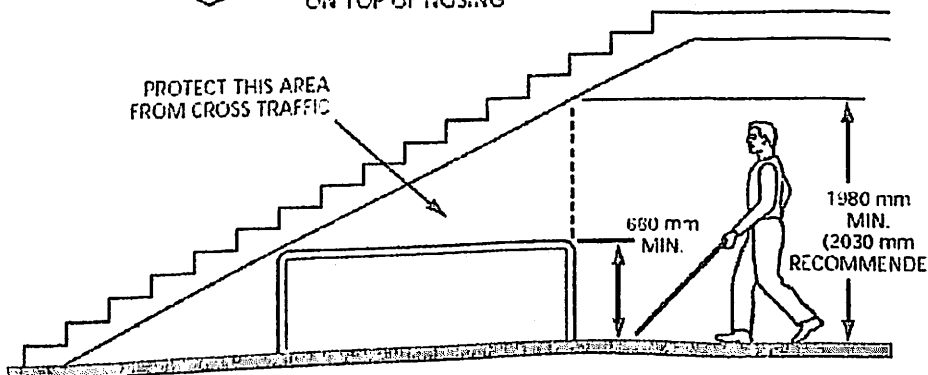



## STEPS / HAND RAILS / BRAILLE INDICATORS

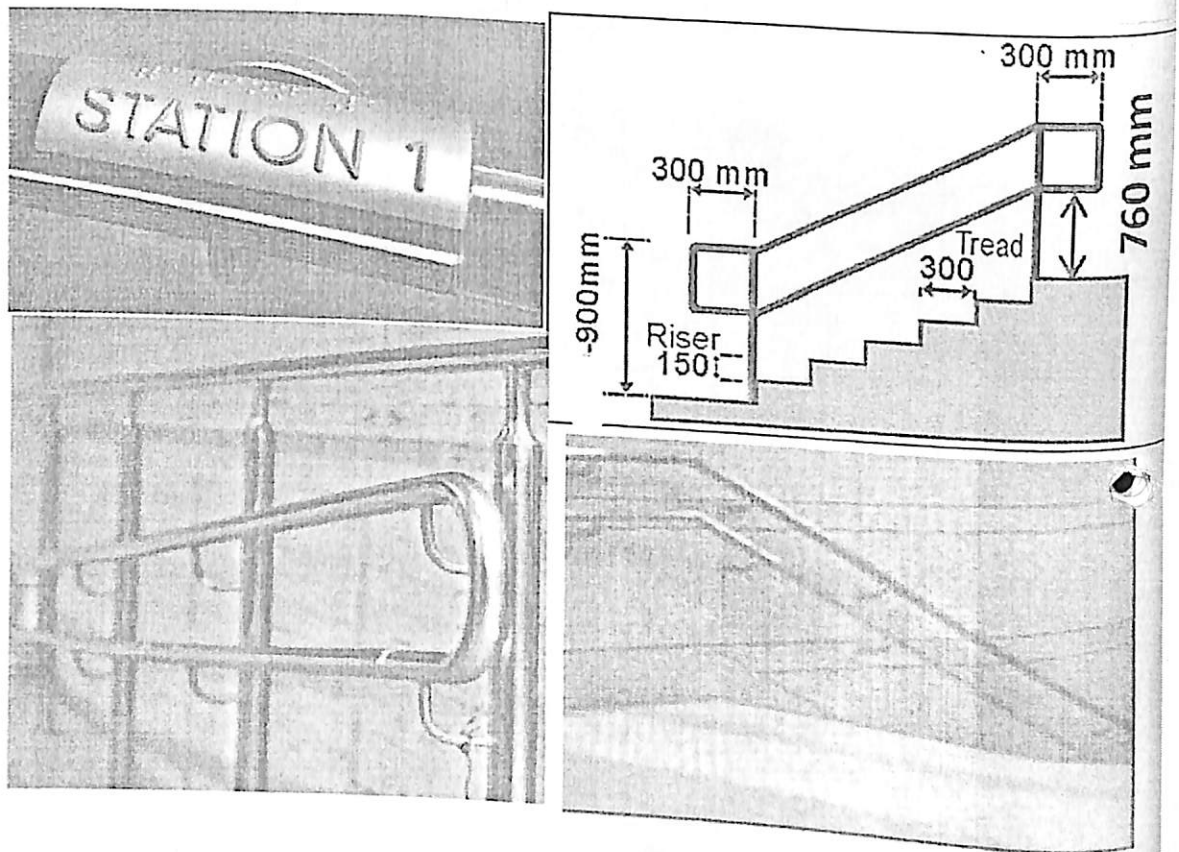

- ❖ Handrails to be provided on both sides of all ramps / existing stairs in SS as shown, with circular section and 50 mm dia.
- ❖ Handrails to be extended by 300 mm beyond the steps / ramps Handrails to be provided everywhere at 2 heights - 900 mm and 760 mm both
- ❖ Handrails to be given a colour that contrasts with the surrounding wall
- ❖ Tactile strips/Braille plate identifications to be provided on the handrails to indicate locations.
- ❖ Accessible directional, multilingual and tactile signage to be provided as per standards.
- ❖ Floor wise key plans are proposed next to steps.

# DOORS / CORRIDORS / ENTRANCE / EXIT.

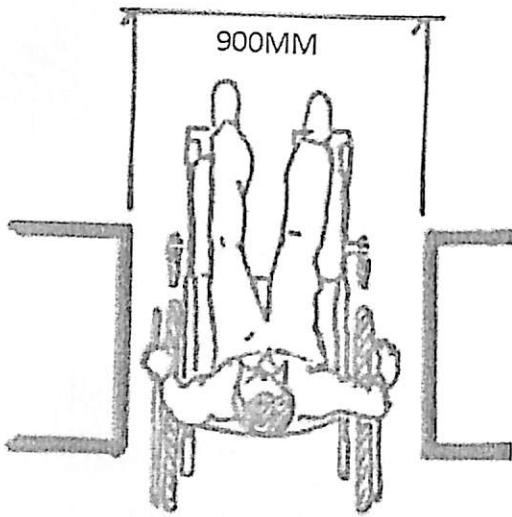

MINIMUM CLEAR WIDTH OF OPENING

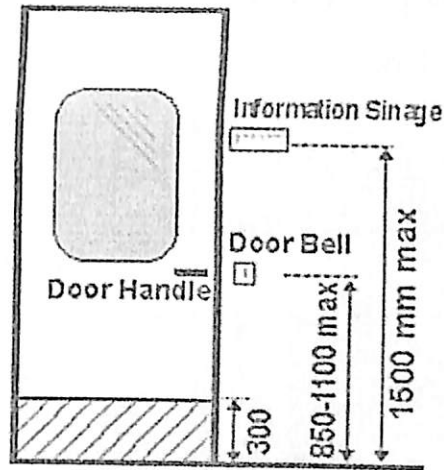

KICKPLATE DETAIL

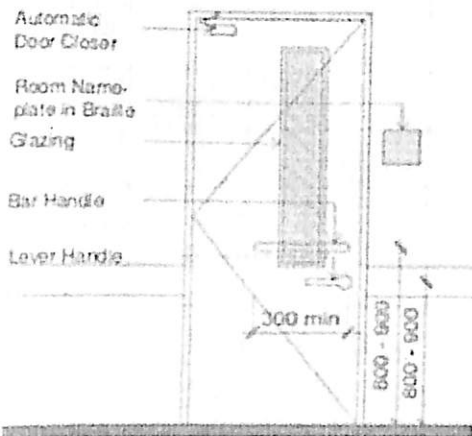

LEVER HANDLE POSITION

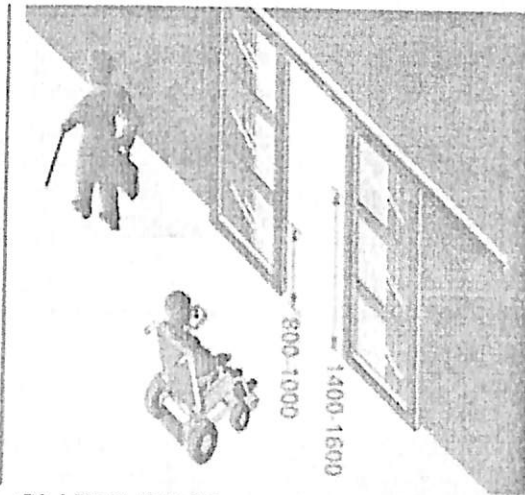

GLAZED DOORS WITH CLEAR BAND

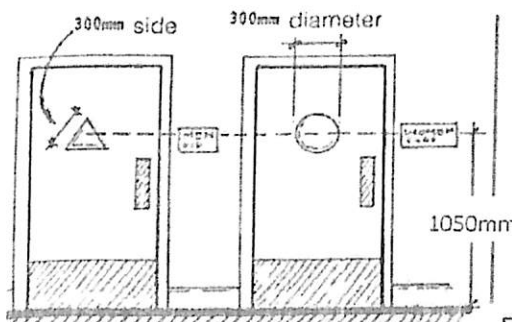

SIGNAGE ON TOILET DOORS

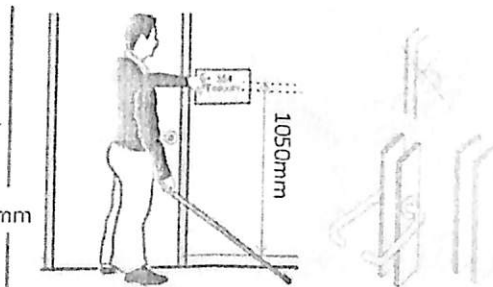

BRILLE SIGNAGE POSITION AND RECOMMENDED HANDLES

# ACCESSIBLE TOILETS

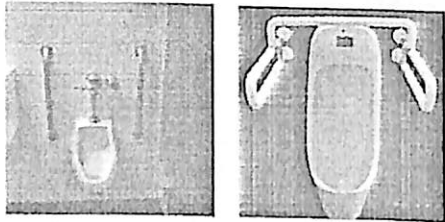

EXAMPLES OF GRAB BARS FOR URINALS

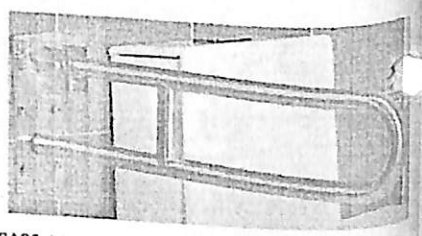

EXAMPLES OF GRAB BARS: L TYPE AND FLIP DOWN



EXAMPLE OF SHOWER SEAT

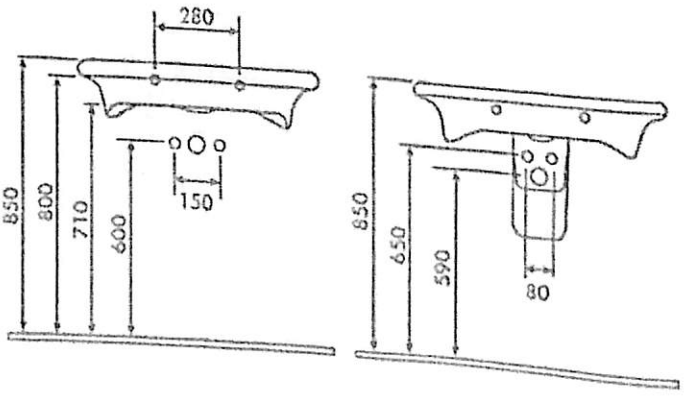
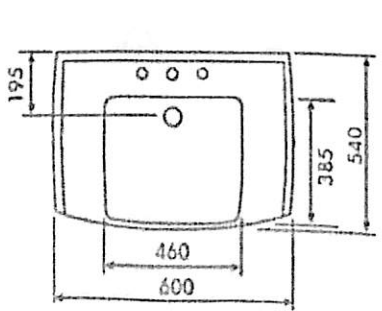
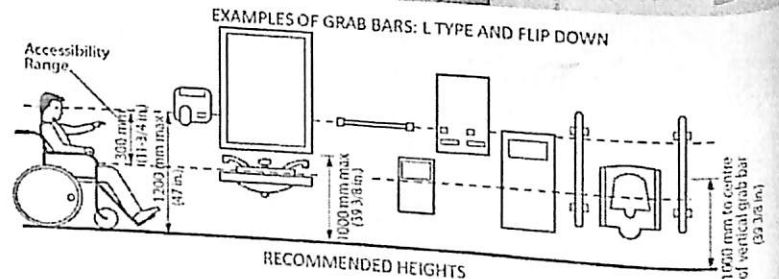

## ACCESSIBLE TOILETS

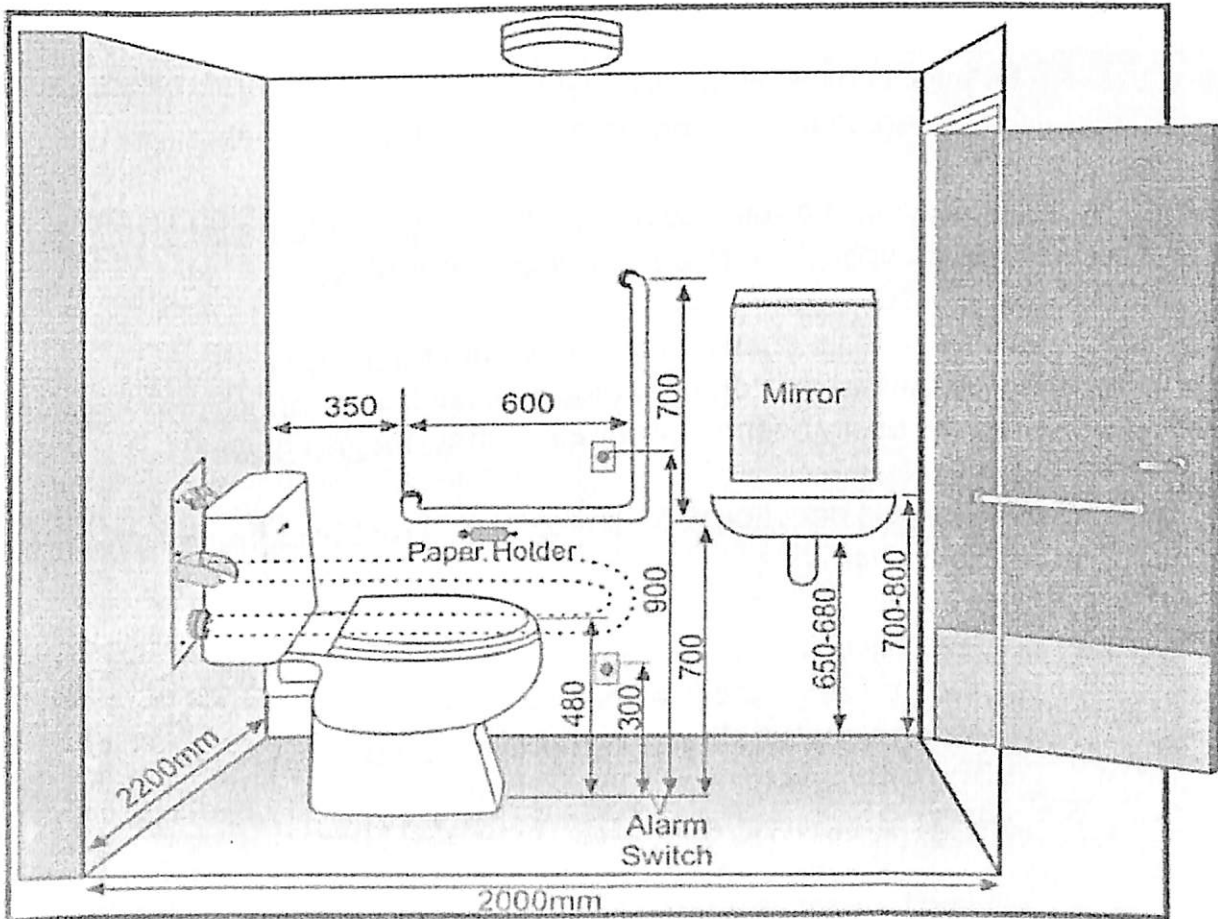

- ❖ The grab bars should be installed near WC at the transfer side, at a height between 750 - 850 mm. Grab bar should not have glossy or reflective surface (as these are highly slippery to hold), but must be in Matt finish or brush finish.
- ❖ Platforms near urinals to be removed.
- ❖ At-least 1 urinal height to be lowered to 650mm keeping children in mind.
- ❖ A switch near the WC (one at 300mm and the other at 900mm from the floor level), which activates an emergency audio alarm ( at the reception / attendants desk, etc. )
- ❖ A toilet paper dispenser should be so installed as to be easily used by a person with physical impairments sitting on the toilet.

## ACCESSIBLE TOILETS

- ❖ Fittings, such as soap dispenser, electric hand dryer and mirror, should be low enough for a wheelchair user to use comfortably.
- ❖ The accessible Toilet cubicle / WC doors should have double swing (should open outside also) and lever handles.
- ❖ Locks to toilet doors or cubicle should be a type that can be opened from outside in case of emergency. Lock lever should be of the type that can be easily opened by person with weak grip power.
- ❖ Accessible directional, multilingual and tactile signage to be provided as per standards.
- ❖ The accessible washbasin should be mounted at a height between 750-850mm. The washbasin should be installed at a distance of at least 400mm from the side wall. There should be clear knee space of at least 650-750mm height x 750mm width x 200mm depth under the wash basin.
- ❖ At-least 1 basin height to be lowered to 650mm keeping children in mind.
- ❖ The wash basin should have lever type taps. Basin taps should be placed at the centre of the basin.
- ❖ Mirror to be provided and installed at a height of 900 mm.
- ❖ Mirror inside accessible toilet should be slightly tilted towards the floor for use by the
- ❖ U-shaped folding grab bars are proposed on the both side of the wash basins.



# ACCESSIBLE TOILETS



## SIGNAGE GUIDELINES FOR TOILET DOORS



**Unisex Toilet**

UNISEX TOILET



**WOMEN**



**MEN**



**DRINKING  
WATER**



**NURSING  
MOTHERS**

## ACCESSIBLE TOILETS

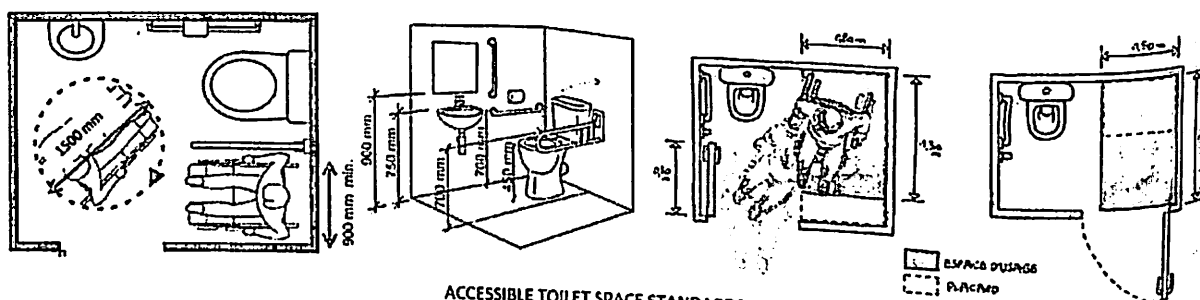

ACCESSIBLE TOILET SPACE STANDARDS

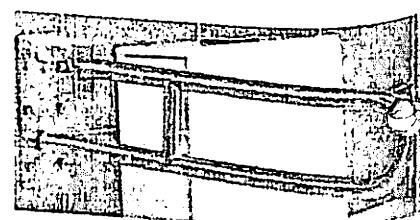
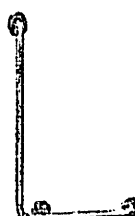
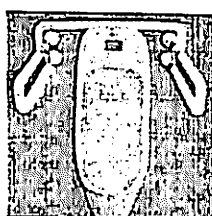

### Provisions for Persons with Physical Disability in General Toilets

- ❖ At least one western WC to be provided in every general toilet block.
- ❖ Folding, U shaped grab bars should be provided to at least one urinal, one basin and inside each toilet block.
- ❖ At least one basin and mirror and one urinal should be mounted at a lower level.

### Grab bars

- ❖ A grab bar should be of preferably in SS, 32 mm diameter/width and strength such that it may easily be grabbed and used as a support.
- ❖ Grab bars should be in a colour that contrasts with the surrounding area.
- ❖ Grab bars should be installed to resist a force of at least 1.3 KN (130 KG) applied vertically or horizontally.

# LIFTS AND CONTROLS

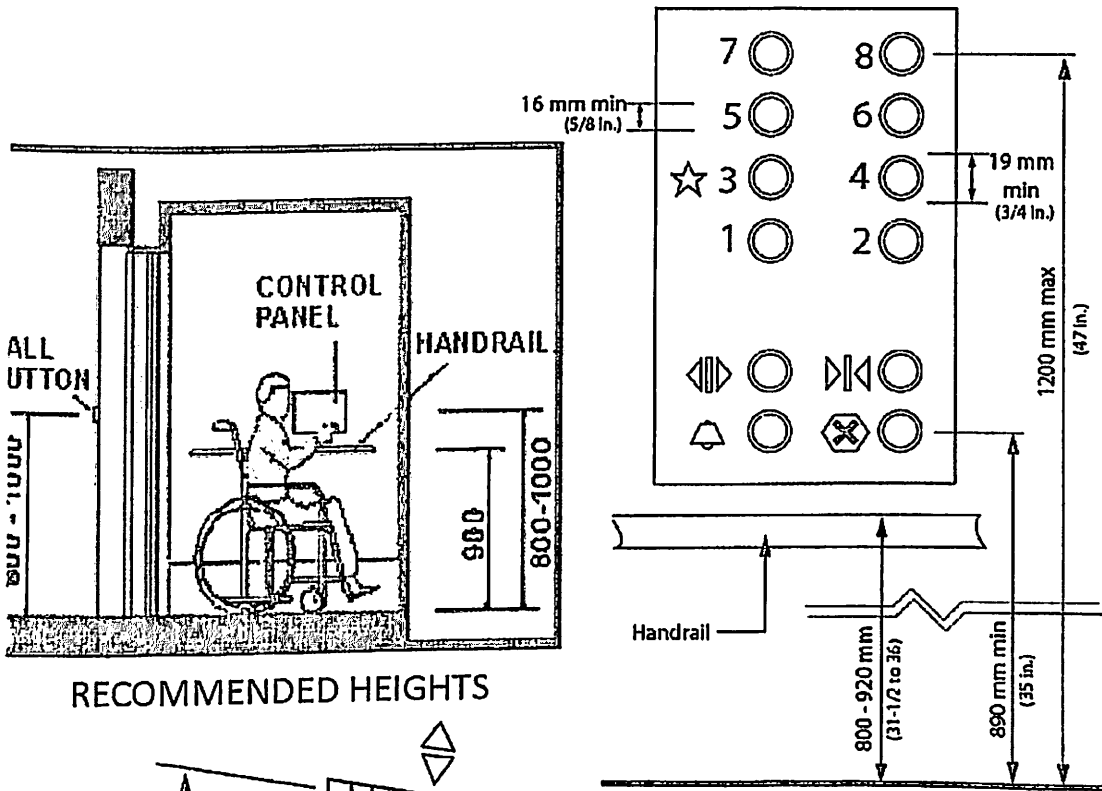

## CONTROL PANEL

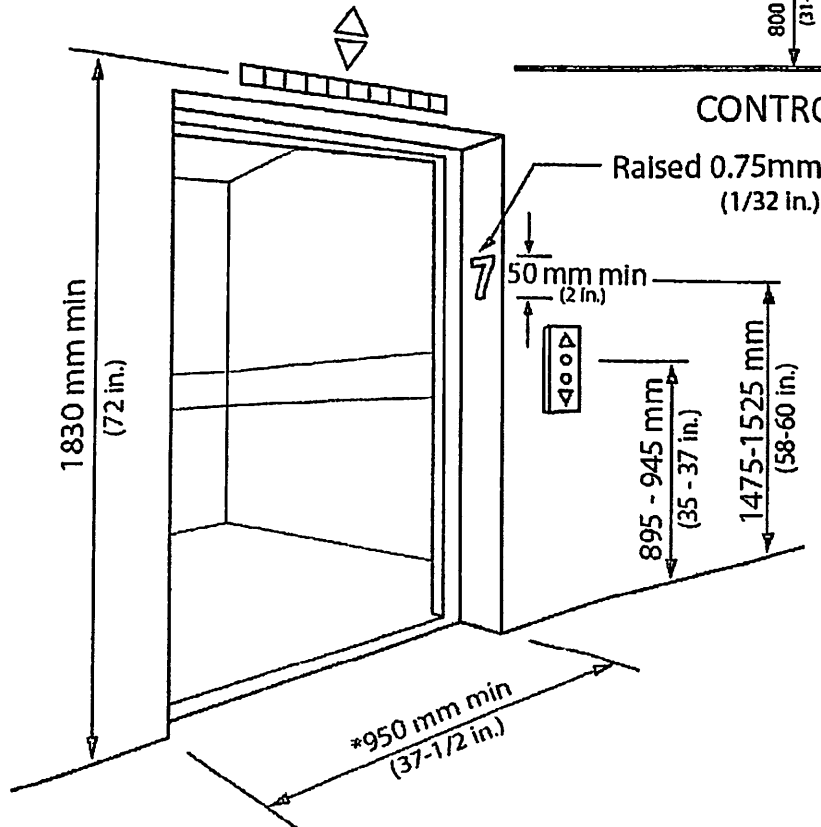

## **WAYFINDING SIGNAGES / TACTILE AUDIO LAYOUTS/ FLOOR DIRECTORIES.**

### **Signage Disposition**

Signage should be adequately provided at eye catching locations at an appropriate height and with an appropriate size.

All Braille and tactile signage to be placed between the height of 900 mm and 1500mm, with ideal location at 1050 mm above the finished floor level, located alongside the door at the latch side.

Directional signage should be provided at wayfinding decision points.

### **Maps and Directories**

Adequate maps and directories, with graphical and text display, braille and audio types, at all entrances and inside spaces can help users to recognize their present position and assist in orientation and wayfinding.

Accessible routes to major functional areas for the disabled user groups should be indicated, including positions for dropped kerbs, ramps, and lifts.

### **Graphical Details**

Contrasting colors should be used for the signs against its background. Pictorial signs should be provided in addition to words and letters.

Words and letters should be of adequate size, height, boldness and suitable fonts for legibility.

Graphics and wordings should be informative and easy to comprehend.

Upper and lower case lettering are considered more legible than capitals alone. Text should be kept short and simple and use recognized symbols for standard features.

### **Directory and Floor Plan**

Directories and floor plans, where provided, should be located at the main entrance to a building, or in a designated place on the floor of entry, and at other strategic locations on different floors and levels. Although they should be located at a prominent position, they should not obstruct the general pedestrian flow.

Bottom level of directories should be at a maximum height of 900mm from floor level. They may be free standing or wall mounted and with 'You are here' indicated. For free

standing ones, they should ideally be slightly inclined from the horizontal, in line with the building's orientation.

### **Visual Directory and Map**

The directory should show the layout plans in simplified form indicating individual rooms, entrances and circulation areas, toilets and other accommodation.

Floor levels should be represented in graphical form and reflected in the directory. For good legibility, the information surface of the directory should be faced with non-reflective and glare resistant material.

Characters and symbols should contrast with their background.

### **Tactile Map**

Tactile maps should be considered at major locations showing directions to the building. In buildings where finding locations independently on a routine basis is a necessity, tactile maps or prerecorded instructions containing information on locations of main entrances, toilets and other major facilities can be very helpful to visually impaired people.

## **WAYFINDING SIGNAGES / TACTILE AUDIO LAYOUTS/ FLOOR DIRECTORIES.**

### **❖ SIGNAGE/WAYFINDING**

- ❖ Signs should be located where they are clearly visible.
- ❖ External signs should be placed in logical and visually unobstructed locations , while ensuring that growth of adjacent foliage will not interfere with visibility.
- ❖ Signage should be in contrasting colours in distinct relief to allow visually impaired persons to obtain the information by touch.
- ❖ Simple symbols and contrasting colours which are universally recognized should be used, e.g. green for safety or go, yellow or amber for risk or caution, and red for danger.
- ❖ Efforts should be made to locate signs where the reader does not obstruct circulation paths .
- ❖ Pictorial signs should be located at major junctions throughout the building for easy way finding .
- ❖ Prominent visible signage using the international symbol of accessibility, identifying accessible entrance and exit, reserved car
- ❖ parking, presence of toilets for persons with disabilities, drinking water fountain, stairs, lifts and availability of special services to be provided at all strategic locations.
- ❖ Directional signs in the reception/lobby/corridors/stairs indicating the location of accessible facilities like drinking water fountain, toilets and emergency exits to be provided.
- ❖ The signage size to comply with not less than 60 mm for doors,110 mm for corridors and 200 mm for external use.
- ❖ All visual signage in the building to be uniform and with high color contrast. Reflection can be avoided
- ❖ by using matt surfaces.
- ❖ All signage should be multi lingual, provided in English, Hindi and local language and provided with Braille and Tactile supplements.



## WAYFINDING SIGNAGES / TACTILE AUDIO LAYOUTS/ FLOOR DIRECTORIES.

### Way Finding And Signage Strategy

Way finding and signage strategies should include the following:-  
Information about services and facilities.

Direction to facilities and functional spaces, service counters , exits and key areas.

Identification including room signs and room numbers, facilities and equipment, stair signs and floor numbers.

Safety notice such as warnings, Prohibitions, Hazards, fire exits and refuges.

Words, pictorial signs and symbols should be used consistently within the same site and building.

Such facility should be identified by international symbols of accessibility.

Wayfinding information can be provided in a range of alternative formats. These include, for example, large print maps, tactile directories with audio-described directions or raised letters on signs.

Wayfinding signage should use large sans serif text set in good visual contrast to a matt background.

Wayfinding signage should use simple language, with upper and lower case letters and should be supported by internationally recognised pictograms or symbols.

Inaccessible routes shall have directional signage to indicate the route to the nearest accessible entrance.

Where illumination of a sign is needed, the light source should be shielded from the viewer to prevent glare .

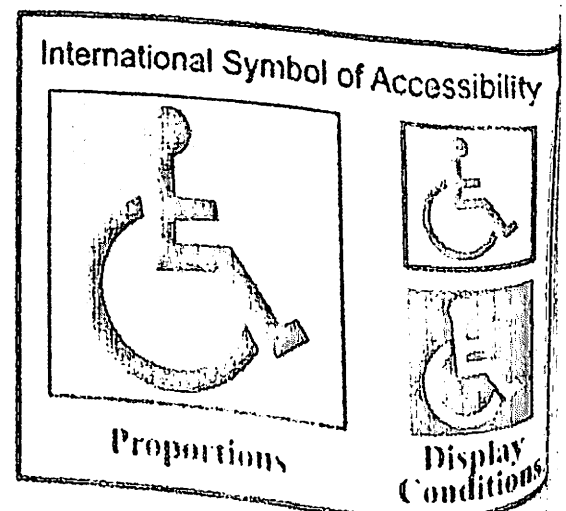
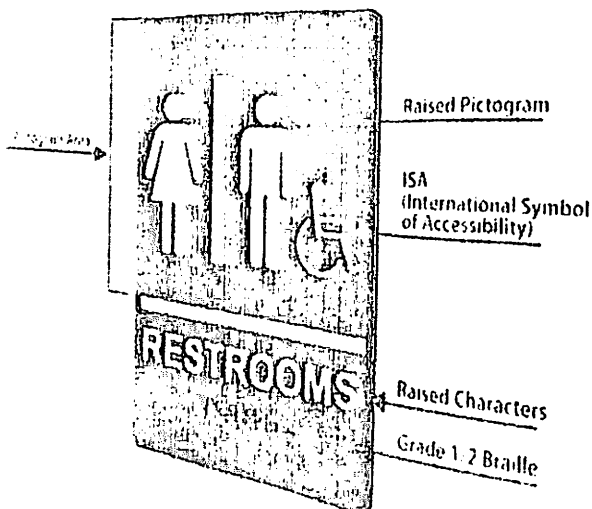

# STANDARD WAY FINDING SIGNAGES & POSITIONS

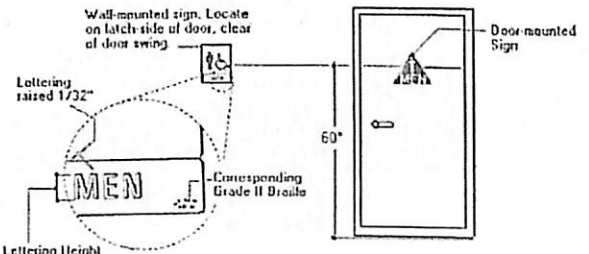
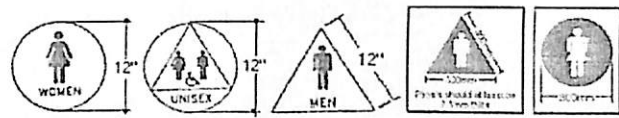
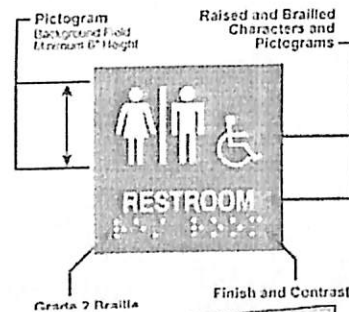
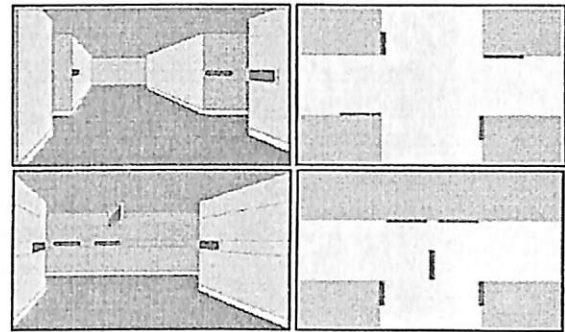
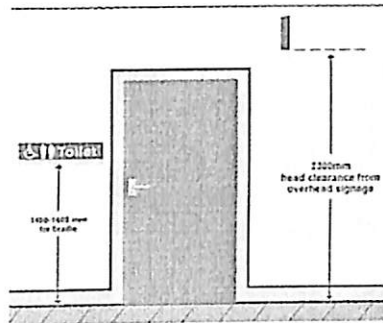
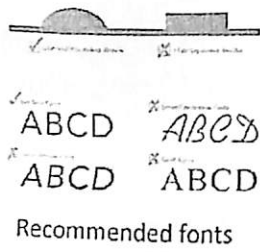

	Size	Viewing distance
	Size: Landscape 300 x 100mm Portrait: 200 x 300mm	Viewing distance up to 15 meters
	Size: Landscape 400 x 150mm Portrait: 300 x 400mm	Viewing distance up to 15 meters
	Size: Landscape 400 x 200mm Portrait: 400 x 600mm	Viewing distance up to 20 meters

Viewing distances

## 10 SYMBOLS FOR SANITARY FACILITIES

Details of Signage on Doors / Toilet doors

### 6.4 Universal Signage

To make signage universally usable, following components must be kept in mind:

- Colour contrast Signs
- Character, Content and Layout
- Pictograms and accessibility symbols
- Positioning
- Viewing Distance
- Lighting (measured in lux)
- Material and surface finish
- Alternative formats etc. embossed letters with Braille (Audio/ Visual information, Maps and models)

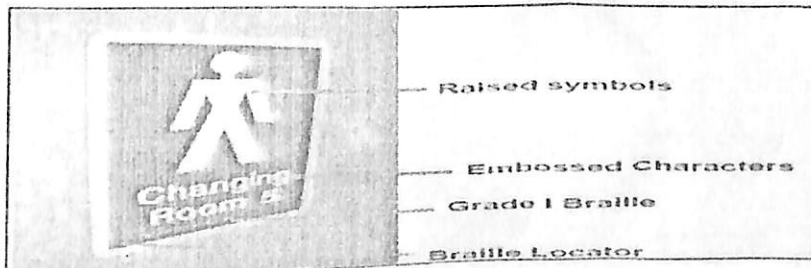

Figure 6-7: Signage with embossed letters and Pictogram

## STANDARD WAY FINDING SIGNAGES & POSITIONS

### 6.4.6 Signage material

- Signage Material should be non-reflective, preferably matt finish. It should have non-glary and non-glossy surface. Natural and artificial light should be such so as not to produce glare on the signage surface.
- The material of all signage should be chosen so as to reduce wear and tear and possible damage by vandalism and at the same time easy to maintain. Some suggested materials for signage are wood, acrylic, Aluminium Composite Panel (ACP).

Generally Acrylic signs Are Used as Braille in ACP sheet is Difficult

### 6.4.7.2 Maps & Models

- A map or model can be particularly helpful, especially to visually impaired people who may be unable to read signs, and to people with hearing impairments who may not be able to understand verbal directions.
- A tactile map or model is a useful way of providing information to visually impaired people and people with hearing impairments who wish to navigate around a building.

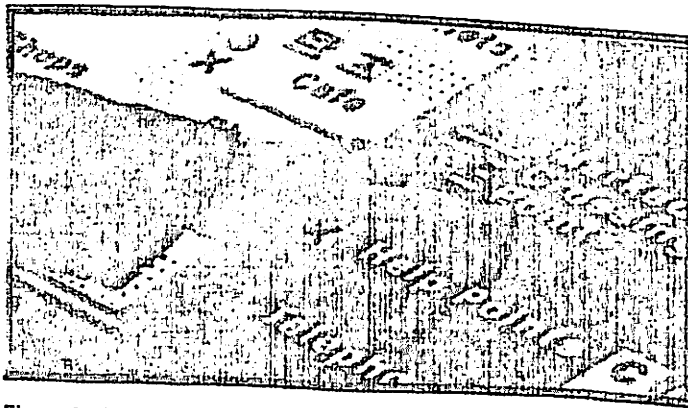

Figure 6-22: Tactile map

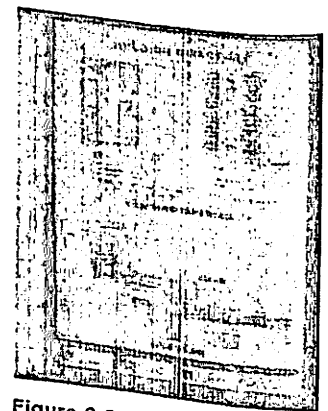
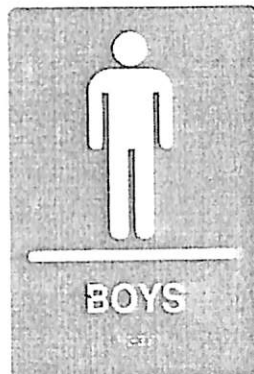
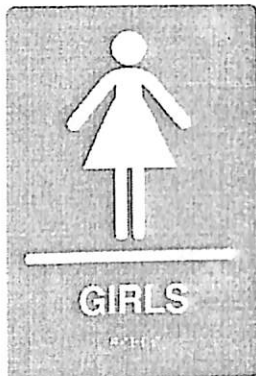
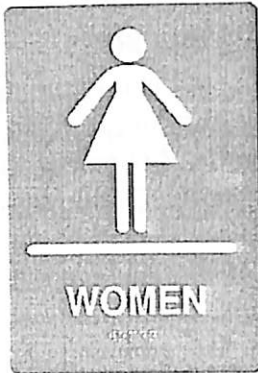
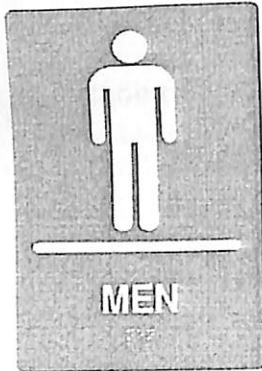

Figure 6-23: Tactile and Audio map

STANDARD SIGNAGES (REFERENCE ONLY)



# EMERGENCY EVACUATION

## RECOMMENDATIONS

- ❖ Emergency evacuation strategies, that include provision for people with disabilities, should be developed for the entire site.
- ❖ Emergency evacuation strategies should consider the particular difficulties faced by people with disabilities - on recognition time, response time and movement time.
- ❖ There should be a step free or ramped accessible evacuation route identified leading to the exit or the ramp or to the refuge area.
- ❖ Where the site covers more than one level evacuation chairs should be provided with staff trained in their correct use.
- ❖ There should be sufficient levels of trained people on site to manage an evacuation strategy.
- ❖ Emergency exits, access and escape routes should be clearly signposted with directional arrow signs.
- ❖ Escape signs should be well lit and have tactile surfaces.
- ❖ Emergency exit routes should be on level ground with no obstacles.
- ❖ Evacuation plans should be prominently displayed. The plan should be of right size and easy to read .
- ❖ The evacuation plans and building maps should be available in tactile Braille formats
- ❖ Sufficient number of fire extinguishers should be provided at the height between 1000mm and 1500mm .
- ❖ The alerting system should be both visual and audible.
- ❖ The alerting buttons should be between 600-1200mm from the floor and should have a high contrast with the wall.
- ❖ Consideration can be given to other ways of raising the alarm including visual alarms, paging system, vibrating devices and tailoring of the sound frequencies delivered.
- ❖ Refuge areas can be provided within protected stair enclosures.



## **GENERAL RECOMMENDATIONS**

### **EVALUATION OF SERVICE**

- ❖ Disability sensitization sessions should be part of the staff induction program.
- ❖ Staff should be trained to assist persons with disabilities, including persons with learning disabilities.
- ❖ Staff should be trained in basic Indian sign language.
- ❖ Staff should be aware of the accessible facilities that are available and know how to operate them.
- ❖ All accessibility equipment should be checked regularly and maintained well.
- ❖ There should be a procedure for a client with disabilities to lodge a complaint or make suggestions.
- ❖ There should be a plan to improve accessibility over a set timeframe.
- ❖ Trained live assistance should be available in premises for all disability constituencies where it may be required.
- ❖ There should be an equal opportunities policy within the organization to promote the employment of staff with disabilities.
- ❖ Policy should include commitment to reasonable adjustment of work place environment to accommodate new staff and clients with disabilities.
- ❖ Organization should have disability focal person in charge who manages the concerns of employees and clients with disabilities.

## GENERAL RECOMMENDATIONS

### INFORMATION AND COMMUNICATION

- ❖ The website should provide information about the building/service and should comply with web accessibility standards
- ❖ There should be the information detailing all the accessible facilities in the building with photographs
- ❖ All publications/brochures should be available in alternate accessible formats such as:
  - ❖ Braille, large Print, audio, pictorial (wherever possible), easy-to-read, plain language, available in Hindi & English, accessible electronic formats that can be shared over email or mobile platforms.
- ❖ Printed service related documents such as forms, menu cards, etc. should be in accessible formats.
- ❖ There should be an option of filling forms electronically through an accessible software.
- ❖ Staff members should be trained in Indian Sign Language interpretation. If not, then Sign language interpreters should be available on call.
- ❖ Assistive technology such as Loop hearing systems, Audio orientation tools, interpretative video's or audio tours in with captioning or sign language, wheelchairs etc. should be available.
- ❖ There should be adequate lighting and no glare for persons with low vision.
- ❖ Adequate support is available for persons from different cultures, learning disabilities, those not formally educated, in all the above provisions.
- ❖ Adequate support is available for persons from different cultures, learning disabilities, those not formally educated, in all the above provisions.

# GLOSSARY

## GLOSSARY

**Access Aisle-** An accessible pedestrian space between elements, such as parking spaces, seating and desks that provides clearances appropriate for use of the elements.

**Accessible-** A site, building, facility, or portion thereof that complies with these Guidelines and that can be approached, entered and used by all people.

**Accessible Route-** A continuous unobstructed path connecting all accessible elements and spaces in a building or facility that can be negotiated by a severely disabled person using a wheelchair and that is also safe for and usable by people with other disabilities. Exterior accessible routes may include parking, access aisles, curb ramps, walkways and ramps. Interior

accessible routes may include corridors, ramps, elevators, lifts, and clear floor space at fixtures.  
**Accessible Signage-** Any visual way finding system incorporates architecture, landscape design, lighting, landmarks and orientation points. Signage is one key element of an effective way finding system and should be accessible to all users including people with disabilities.

**Ambulatory Disabled-** A person who is able, either with or without personal assistance, and who may depend on prostheses (artificial limbs), orthotics (callipers), sticks, crutches or walking aids to walk on level or negotiate suitably graded steps provided that convenient handrails are available.

**Automatic Door-** A door equipped with a power operated mechanism and controls that open and close the door automatically upon receipt of a momentary signal. The switch that begins the automatic cycle may be photoelectrical device, floor mat, sensing device, or manual switch mounted on or near the door itself.

**Beveled-** Smooth, slanted angle between two surfaces; for example, a slant or inclination between two uneven surfaces to allow easier passage of a wheelchair.

**Braille Signage**(Ron Apelt, John Crawford and Dennis Hogan, 2007)- Is a specialist way finding device that incorporates Braille as a primary source of information for people who are vision impaired and maybe aided with raised tactile lettering, maps or pictorial images.

**Braille-** The Braille system is a method that is widely used by blind people to read and write.  
**Circulation Path-**An exterior or interior way of passage from one place to another for pedestrians, including walkways, hallways, courtyards, stairways and stair landings.

**Clear - Unobstructed**

**Colour Contrast-** The basic guidelines for making effective colour choices are based on the hue value of the colours. The most commonly used methods of achieving colour contrast incorporate either 'harmonising' or 'contrasting' colour combinations.

**Cross Slope-** Cross slope or camber is a geometric feature of pavement surfaces: the transverse slope with respect to the horizon. It is a very important safety factor. Cross slope is provided to provide a drainage gradient so that water will run off the surface to a drainage system such as a street gutter or ditch.

**Disability-** is an umbrella term for impairments (WHO, 2004), activity limitations, and participation restrictions, denoting the negative aspects of the interaction between an individual (with a health condition) and that individual's contextual factors (environmental and personal factors). Disability is neither simply a biological nor a social phenomenon but arises from the relationship between health condition and context.

**Grab Bars-** A bar used to give a steadying or stabilizing assistance to a person engaged in a particular function.

**Handrails-** A rail used in circulation areas such as corridors, passageways, ramps and stairways to assist in continuous movement.

**Hue - Hue** is the perceptual attribute associated with elementary colour names. Hue enables us to identify basic colour categories such as blue, green, yellow, red and purple. People with normal colour vision report that hues follow a natural sequence based on their similarity to one another. With most colour deficits, the ability to discriminate between colours on the basis of hue is diminished.

**Individual Washrooms-** A compartment having the basic requirements of a water closet compartment, washbasin and other essential washroom accessories as required by people with disabilities.

**Induction loop -** An induction or inductive loop is an electromagnetic communication or detection system which uses a moving magnet to induce an electric current in a nearby wire. Induction loops are used for transmission and reception of communication signals, or for detection of metal objects in metal detectors or vehicle presence indicators. A common modern use for induction loops is to provide hearing assistance to hearing-aid users.

**International Symbol of Access-** Also known as the (International) Wheelchair Symbol, the International Symbol of Access consists square overlaid with a stylized image of a person using a wheelchair. The symbol is often seen where access has been improved, particularly for wheelchair users and other mobility impaired persons.

## GLOSSARY

**Kerb** - A side barrier to a trafficable surface or is the edge where a raised sidewalk/footpath, road median, or road shoulder meets an unraised street or other roadway.

**Kerb Ramp**- A short ramp cutting through a curb or built up to it or a Kerb is a drop, with walk way, at a gradient no greater than 1:10 on both sides of necessary and convenient crossing points (figure 2 & 5). Width should not be less than 1200mm. If width (X) is less than 1200mm, then slope of the flared side shall not exceed 1:12.

**Knurled Surface**- Roughened area, often in a crisscross pattern; used on either doorknobs or grab bars. On doorknobs, it is used to provide tactile clues to visually impaired persons to indicate that passage leads to an area of danger. On grab bars it is used to improve grasp and to prevent slipping.

**LRV**- Light reflectance value (LRV) is the total quantity of visible light reflected by a surface at all wavelengths and directions when illuminated by a light source.

**Luminosity Contrast**- Also known as tonal contrast is the most important element that assists people with vision impairments to distinguish between two different surfaces. A minimum difference of 26 points in the Light Reflectance Value of colours of two architectural surfaces produces an adequate luminosity contrast that is perceivable by persons with vision impairments.

**Marking a parking space reserved for vehicles used by Persons with Disabilities**  
**Marking a public lavatory with facilities designed for wheelchair users**

**Lux** - Is the standard unit of illumination. It is used as a measure of perceived intensity of light.

**Operable Parts**- A part of a piece of equipment or appliance used to insert or withdraw objects, or to activate, deactivate, or adjust the equipment or appliance (for example coin slot, pushbutton, handle).

**Passing places**- a space on footpath, single track road or one lane road that permits two ways travels when it is not wide enough to allow wheelchairs/vehicles to pass one another.

**Persons with Disabilities**<sup>1</sup>- A Person with Disability is a person with any physical, mental, intellectual or sensory impairment which in interaction with various barriers may hinder full and effective participation in society on an equal basis with others. The term "Persons with Disabilities", consistent with the terminology used in the

1 Rights of Persons with Disabilities Act, 2012: <http://www.dalitstudies.in/2012/02/27/act.php>

**Public Areas** - Interior and exterior rooms or spaces that are made available to the general public. Public use may be provided at a building or facility that is privately or publicly owned.

**Public Use**- Describes interior and exterior rooms or spaces that are made available to the general public. Public use may be provided at a building or facility that is privately or publicly owned.

**Ramp**- An inclined way connecting one level with another.

**Signage**- Any room number, name tag, building directory, or similar object containing a printed message and/or symbol. Signage and signs are used synonymously in this document.

**Space**- A definable area (for example, toilet room, hall, assembly area, entrance, storage, room alcove, courtyard, or lobby).  
**Table Top**- road raised to footpath/footway level at crossing or with leveled.

**Tactile (CRC, 2007)**- Tactile means information and interpretations derived from the sense of touch. This involves sensory transfer through physical contact of the hands or feet with other surfaces, as well as sensory transfers received by contact with non-physical elements such as pressure, wind and temperature.

**Tactile paving/tiles**- (also called Tactile Ground Surface Indicators) provide a distinctive surface pattern of "strips" and "truncated domes" or cones (which are small domes or cones that have had their tops cut off, or truncated) detectable by long cane or underfoot which are used to guide/alert persons with vision impairments of their approach to facilities, streets and hazardous drop-offs. People who are blind or visually impaired are alerted of impending danger from vehicle impact or a grade change.

**Tactile signs (Refer also to Braille Signage)**- Tactile signage incorporates raised text or symbols to enable touch reading by people who are blind, and touch enhancement of visual perception for people who are vision impaired.

**Tactile Guiding Blocks** - These are 300 x 300 mm tiles that incorporate bars that are 5mm ( $\pm$  0.5mm) high, 20mm wide and spaced 50mm from the centre of one bar to the centre of the next. These flat topped bars that are easily detectable underfoot by people with visual impairments. They are used externally to guide people with visual impairments along the circulation path. They may also be used internally in large busy areas such as railway stations and airports.

**Tactile Warning Blocks** - In order to warn persons with visual impairments of the approaching danger, it is recommended to incorporate Tactile Ground Surface indicators.

## **DISCLAIMER**

### **Disclaimer**

Although we have offered the best advice available to us at the time of compiling this audit report, please be advised that due to the ongoing development of legislation in this area, all companies and organizations

should seek continuing advice to ensure that their services and facilities

remain compliant with their statutory obligations.

It is important that professionals with accessibility experience be involved in all stages of the design, construction, renovation and refurbishment process.

Maiara Technologies or its representatives can not accept any responsibility for loss occasioned by reason of non-compliance with the requirements of relevant legislation / rules, if revised in due course.

Service Providers are more likely to be able to comply with their duties if they:

- ❖ Periodically audit physical and non-physical barriers to access.
- ❖ Make appropriate adjustments.
- ❖ Provide training to staff which is relevant to these adjustments.
- ❖ Draw the adjustments to the attention of disabled people.
- ❖ Prepare, and monitor compliance with, an 'Access Implementation
- ❖ Plan taking into account the priority and cost implications highlighted in the audit report, and incorporating considerations to improvise access in planned maintenance and management procedures.
- ❖ Let disabled people know how to request assistance.
- ❖ Regularly review.