

**NIT No.** : **RLAC/2023/443**

**TITLE** : **E-TENDER FOR  
CONSTRUCTION OF  
STEEL STAIRCASE AT  
RAM LAL ANAND  
COLLEGE, NEW DELHI.  
(2ND CALL)**

**OWNER** : **PRINCIPAL, RAM LAL ANAND  
COLLEGE.**

**ADDRESS** : **BENITO JUAREZ ROAD, NEW DELHI-  
110 021**

**WEBSITE** : **[WWW.RLACOLLEGE.EDU.IN](http://WWW.RLACOLLEGE.EDU.IN)**

**TYPE OF TENDER** : **OPEN- E TENDER (TWO COVER  
SYSTEM)**

**ESTIMATED COST  
OF WORK** : **19.59 LAKHS**

**TENDER FEE** : **RUPEES ONE THOUSAND ONLY**

**DATE OF START** : **17-07-2023**

**LAST DATE OF  
SUBMISSION OF  
TECHNICAL BID  
DOCUMENT** : **29-07-2023**

**EARNEST MONEY  
DEPOSIT** : **40,000/-**

**TENDER  
PREPARED BY** : **RANJIT SINGH & ASSOCIATES, 1206 SURYA  
KIRAN BUILDING, 19 K.G. MARG, NEW DELHI  
110001. PH. 011-43560879. RSA1206@MSN.COM**

## Contents

TENDER SCHEDULE.....	2
ELIGIBILITY CRITERIA.....	3
CHECKLIST OF DOCUMENTS TO BE PLACED IN THE TECHNICAL BID.....	4
NOTICE INVITING TENDER .....	5
TENDER ACCEPTANCE (OFFER) LETTER.....	6
BIDDER'S DETAILS .....	8
SPECIAL CONDITIONS OF CONTRACT .....	9
GENERAL CONDITIONS OF CONTRACT.....	12
FORM OF PERFORMANCE SECURITY BANK GUARANTEE BOND.....	24
TURNOVER CERTIFICATE (ANNEXURE 1).....	26
LIST OF APPROVED MAKES FOR CIVIL WORKS .....	27
CONTRACT DRAWINGS .....	28

E-TENDER FOR CONSTRUCTION OF STEEL STAIRCASE AT RAM LAL ANAND COLLEGE, NEW DELHI. (2nd call)

TENDER SCHEDULE		
Validity Of Offer	:	90 Days
Cost Of Tender Document	:	Rs. 1,000
Estimated Cost of The Work	:	19.59 LAKHS
Earnest Money Deposit.	:	40,000/- Payables by D.D. In Favour Of PRINCIPAL, RAM LAL ANAND COLLEGE.. EMD of unsuccessful bidders will be returned.
Start Of Tender Download.	:	Monday, 17 July 2023
Last Date of Tender Download.	:	29-07-2023
Last Date of Submission of Tender.	:	29-07-2023 At 11:00 Am
Date Of Opening of Technical Bid.	:	31-07-2023 At 11:30 Am
Defects Liability Period.	:	24 Months
Contract Time Period.	:	5 Months
Penalty For Delay.	:	Rs. 5,000/- Per Day Up to Maximum Of 10% Of the Cost of The Works.
Minimum Running Account Bill Value.	:	5 LAKHS
Retention Percentage.	:	5%
Performance Guarantee.	:	Before Issue of Letter to Start the Work, Contractor Shall Furnish A Performance Guarantee In The Form Of A Bank Guarantee To The Tune Of Five Percent (5%) Of The Cost Of The Accepted Tender Amount. Bank Guarantee Will Be Kept Valid Up To 24 Months After Completion of The Works.
Contact Details for Clarification Related to Tender.	:	Email: <a href="mailto:Rsa1206@Msn.Com">Rsa1206@Msn.Com</a> Phone. 011-43560879

**ELIGIBILITY CRITERIA**

<b>S. NO.</b>	<b>DESCRIPTION</b>
<b>1)</b>	<b>: BIDDER SHOULD HAVE COMPLETED THREE SIMILAR WORKS EACH COSTING NOT LESS THAN RUPEES 8.0 LACS</b>
	<b>OR</b>
	<b>BIDDER SHOULD HAVE COMPLETED TWO SIMILAR WORKS EACH COSTING NOT LESS THAN RUPEES 12 LACS</b>
	<b>OR</b>
	<b>BIDDER SHOULD HAVE COMPLETED ONE SIMILAR WORKS EACH COSTING NOT LESS THAN RUPEES 16 LACS</b>
<b>2)</b>	<b>: BIDDER SHOULD HAVE AVERAGE ANNUAL TURNOVER (GROSS) OF 10.0 LACS</b>
<b>3)</b>	<b>: BIDDER SHOULD HAVE A SOLVENCY OF RUPEES 8 LACS</b>
<b>4)</b>	<b>: BIDDER SHOULD SUBMIT AN EMD OF RUPEES 40,000/-.</b>

**CHECKLIST OF DOCUMENTS TO BE PLACED IN THE TECHNICAL BID**

<b>S.NO.</b>	<b>DESCRIPTION</b>	<b>CHECK</b>
1)	: COMPANY REGISTRATION DETAILS	<input type="checkbox"/>
2)	: COMPANY PROFILE	<input type="checkbox"/>
3)	: GST REGISTRATION CERTIFICATE COPY	<input type="checkbox"/>
4)	: PAN CARD COPY	<input type="checkbox"/>
5)	: TURNOVER CERTIFICATE (ANNEXURE -1)	<input type="checkbox"/>
6)	: SOLVENCY CERTIFICATE	<input type="checkbox"/>
7)	: VALID COMPLETION CERTIFICATES	<input type="checkbox"/>
8)	: TENDER FEE OF RS. 1000 IN THE FORM OF A DEMAND DRAFT IN THE NAME OF PRINCIPAL, RAM LAL ANAND COLLEGE. <i>ORIGINAL DEMAND DRAFT TO BE SUBMITTED TO THE OFFICE OF THE PRINCIPAL AND SCANNED COPY TO BE UPLOADED ALONG WITH THE TENDER.</i>	<input type="checkbox"/>
9)	: EMD FEE OF RS. 40,000/- IN THE FORM OF A DEMAND DRAFT IN THE NAME OF PRINCIPAL, RAM LAL ANAND COLLEGE. <i>ORIGINAL DEMAND DRAFT TO BE SUBMITTED TO THE OFFICE OF THE PRINCIPAL AND SCANNED COPY TO BE UPLOADED ALONG WITH THE TENDER.</i>	<input type="checkbox"/>

**NOTICE INVITING TENDER**

To

All The Eligible Bidders,

Dear Sir/ Madam,

You are invited to submit your most competitive **ONLINE** Quotation through the Central Public Procurement (CPP) Public Procurement (CPP) portal web site [eProcurement System Government of India](#) in TWO COVER SYSTEM (TECHNICAL & FINANCIAL) on or before the prescribed due date and time for E-TENDER FOR CONSTRUCTION OF STEEL STAIRCASE AT RAM LAL ANAND COLLEGE, NEW DELHI. (2nd call).

Manual Bids shall not be accepted, except for the supportive documents / instruments if any asked in this tender.

The complete details of the tender items are available in the tender document, which can be downloaded from [www.rlacollege.edu.in](http://www.rlacollege.edu.in) and the Central Public Procurement (CPP) Public Procurement (CPP) portal web site [eProcurement System Government of India](#).

The bids are to be submitted ON-LINE through [eProcurement System Government of India](#) up to the due date and time of submission of tender. Any queries related to the tender document should be addressed to the tender inviting authority PRINCIPAL, RAM LAL ANAND COLLEGE..

Any queries relating to the process of online bid submission or queries relating to CPP Portal by bidders should be addressed to 24x7 CPP Portal Helpdesk by using the Toll-Free numbers given in the CPP website.

Sd/-

PRINCIPAL, RAM LAL ANAND COLLEGE.

**TENDER ACCEPTANCE (OFFER) LETTER**

TO,

PRINCIPAL, RAM LAL ANAND COLLEGE.  
Benito Juarez Road, New Delhi- 110 021

Subject: Acceptance in respect of terms and conditions of tender document for E-TENDER FOR CONSTRUCTION OF STEEL STAIRCASE AT RAM LAL ANAND COLLEGE, NEW DELHI. (2nd call).

Dear Sir,

1. I / We have downloaded the tender document(s) for the above-mentioned tender from the website [www.rlacollege.edu.in](http://www.rlacollege.edu.in) / [eProcurement System Government of India](#) .
2. I / We hereby certify that I / We have read every page of the tender document including all terms/conditions/drawings/annexures/forms/appendixes/paras etc. which are part of the contract agreement, and I / We agree to accept all the terms and conditions contained therein.
3. The corrigendum(s) issued from time to time by your organisation has also been taken into consideration, while submitting this acceptance letter.
4. I / We hereby unconditionally accept all the terms and conditions of above-mentioned tender document and corrigendum(s) as applicable.
5. In case any provisions of this letter are found violated, then PRINCIPAL, RAM LAL ANAND COLLEGE. shall without prejudice to any other right or remedy be at liberty to reject my/our bid including the forfeiture of EMD.
6. I / We hereby certify that all statements made and information supplied in the enclosed appendix, annexure, forms/paras etc. furnished herewith are true and correct.
7. I / We have furnished all information and details necessary for demonstrating our qualification and have no further critical information to supply.
8. I / We understand and accept that PRINCIPAL, RAM LAL ANAND COLLEGE. is not bound to accept the lowest bid or any of the bids submitted by the bidders or to give any reasons for their decision.
9. I/We understand and accept that all taxes including GST shall be payable by the bidder/contractor and PRINCIPAL, RAM LAL ANAND COLLEGE. will not entertain any claim whatsoever in respect of taxes.

10. I/We understand and accept that PRINCIPAL, RAM LAL ANAND COLLEGE. reserves the right of accepting the whole or any part of the tender and the bidder/contractor shall be bound to perform the same at quoted rates.
11. I / We understand and accept that in case any information provided by me/us is found to be false/ incorrect, then PRINCIPAL, RAM LAL ANAND COLLEGE. shall be at liberty to reject our bid and without prejudice to any other right or remedy, be at liberty to forfeit the EMD absolutely and I / We shall not have any claim against PRINCIPAL, RAM LAL ANAND COLLEGE. .
12. I/We understand and accept that, if after the tender is accepted, I / We fail to commence the execution of the works within the stipulated time, then PRINCIPAL, RAM LAL ANAND COLLEGE. shall without prejudice to any other right or remedy, be at liberty to forfeit the EMD absolutely and I / We shall not have any claim against PRINCIPAL, RAM LAL ANAND COLLEGE. .

Yours Faithfully,

Signature of Bidder:

Name:

Designation:

Stamp of the Bidder:



**BIDDER'S DETAILS**

<b>S.NO.</b>	<b>DESCRIPTION</b>	<b>DETAIL</b>
1	Name of Company	
2	Address of Company	
3	PAN no.	
4	GSTN no.	
5	Telephone Number	
6	Email Address	
7	Name of Company Owner / Director / Partner	
8	Address of Company Owner / Director / Partner	
9	Telephone Number of Company Owner / Director/ Partner	
<p>I/We hereby declare that the information furnished above is true and correct. In case the above information is found incorrect at any stage, the PRINCIPAL, RAM LAL ANAND COLLEGE. may take appropriate action as warranted.</p>		
Name:		
Designation:		
Stamp & Signatures:		
Place:		
Date:		

## SPECIAL CONDITIONS OF CONTRACT

1. CONTRACTORS are advised to inspect and examine the site and the surroundings and satisfy themselves before submitting their Tender as to the nature of the ground and sub-soil (so far as practicable), the form and the nature of the site, the means of access to the site, the accommodation they may require and in general shall themselves obtain necessary information as to the risks, contingencies and other circumstances which may influence or affect their Tender. CONTRACTORS shall be deemed to have full knowledge of the site, whether they inspect it or not and no extra charge consequent to any misunderstanding or otherwise shall be allowed.
2. Submissions of the Tender by the CONTRACTOR implies that he has read all contract documents and has made himself aware of the scope and specifications of the work to be done and local conditions and other factors bearing on the execution of the works.
3. On acceptance of the Tender, earnest money will be treated as a part of the security. In addition, contractor shall furnish performance guarantee in the form of an F.D.R or bank guarantee of 5% of the accepted Tender cost in favour of PRINCIPAL, RAM LAL ANAND COLLEGE. before issue of letter to start the work.
4. The CONTRACTOR, whose Tender is accepted, shall permit PRINCIPAL, RAM LAL ANAND COLLEGE. at the time of making any payments to him for works done under the contract to deduct towards security deposit such sum as will along with the amount of earnest money already deposited amount to the following % of the cost of the work:  
-
  - a) 5% of the bill amount.
  - b) 50% of the security money will be released along with the final bill and the balance after expiry of the successful performance of the Defects Liability Period of two year without any interest.
  - c) TDS on Income Tax/GST/Labour Cess etc. as applicable.
5. PRINCIPAL, RAM LAL ANAND COLLEGE. will return the earnest money where applicable to every unsuccessful contractor on return of all the Tender documents without any interest.
6. TDS on Income tax/GST/Labour cess etc. as applicable shall be deducted from the payments made to the bidder/contractor and TDS certificates shall be issued by the owner.
7. Water and electricity shall be arranged by the tenderer himself. In case it is available, the same can be provided by the College authorities at one point. A recovery @ 1 % for electricity and 1% for water charges shall be recovered on gross value of work done.

8. The work shall be carried out in accordance with the phasing plan approved by the PRINCIPAL, RAM LAL ANAND COLLEGE. to avoid any disturbance. The site is expected to be handed over immediately. The contractor will prepare and submit a Phasing Plan with Bar Chart with targeted dates of completion for all the activities and get it approved from the PRINCIPAL, RAM LAL ANAND COLLEGE. within 7 days of award of contract.
9. The rates shall be inclusive of 2 years ON SITE comprehensive defect liability maintenance including all tools, plants, parts, labour, supervision and technical support.
10. The work shall be carried out as per specifications in the Tender schedule/latest C.P.W.D. Specifications, along with the correction slips; issued up to date of acceptance of Tender in case of doubt the decision of the Architect shall be final and binding on the Contractor.
11. The Contractor shall carryout the work in stages as to cause minimum disturbance to the Owner. Contractor shall be responsible for any damage to the equipment or structures, injury to the personnel during the progress of the work and he shall be liable to pay compensation as may be decided by the PRINCIPAL, RAM LAL ANAND COLLEGE. or his authorized representative in respect of such damages /injuries.
12. The serviceable materials out of the dismantled materials if any will be the property of the PRINCIPAL, RAM LAL ANAND COLLEGE. and all such materials shall be properly stacked by the Contractor as directed by the Engineer-in-charge. Decision of PRINCIPAL, RAM LAL ANAND COLLEGE. or his authorized representative on the serviceability of the dismantled materials shall be final and binding on the Contractor.
13. All labour Employed by the Contractor shall be covered by the workman's compensation act. Any death, injury or mishap to the workmen of the Contractor will entirely be the Contractor's responsibility and the College, shall not be liable to pay any damages for the same.
14. Contractor shall take adequate safety precautions to avoid any accident etc. at site. Shall erect proper barricades, sign boards, lights, etc. shall provide safety belts, safety shoes, head gears (helmet I.S.I standard) and shall be fully responsible for any criminal & civil liabilities. All safety arrangements are to be made by contractor at his own cost.
15. No labor or material rate escalation claims will be entertained from the contractor as this work has to be completed within 5 months from the date of commencement of work at site.
16. Rates quoted shall be applicable equally to all floors and shall include all lifts and leads. No extras on this account shall be payable.

17. The contractor shall provide training for operation and maintenance of Equipment's to the Owners representatives free of cost, where required.
18. Rates quoted by the contractor shall be inclusive of all items of work mentioned in the BOQ and Any work, supplies or services which might have not been specifically mentioned in the BOQ but are necessary for entire completion of the work shall be executed / provided/ rendered by the CONTRACTOR without any Extra cost and within the time schedule specified. Rates quoted shall be deemed to include such elements of labour and materials necessary to complete the items of work in all respects.
19. Contractor shall submit only computerized Bills supported with computerized measurement sheets in A4 size hard copy prints and soft copy in Microsoft Excel Format. Manual Handwritten bills or measurement sheets will not be accepted.
20. Labour Camp will be arranged by the contractor outside the Site of work at his own cost.
21. PRINCIPAL, RAM LAL ANAND COLLEGE. College reserves the right to decrease the items of work, change the specifications of works or remove the entire section of work as may be deemed necessary to finish the works within the available budget.

## GENERAL CONDITIONS OF CONTRACT

Definitions: the contract document consists of the agreement, the special and general conditions of the contract, specifications and bills of quantities including all modifications and the contract drawings prepared by the Architect from time to time

1. The site: shall mean the site of contract work.
2. Bidder / Contractor: Shall mean the person or business that agrees to conduct the contract work under the terms of the contract.
3. Sub-Contractor: includes those who have a direct contract with the Contractor.
4. Notice: written notice shall be deemed to have been served if delivered in person to a member of the Contractors firm.
5. Owner: PRINCIPAL, RAM LAL ANAND COLLEGE.
6. Work: the term “work” includes both labour and material of the Contractor/Sub-Contractor.
7. Time limits: time limits stated in the contract are essence of the contract.
8. Law: law of the place of work shall govern the construction under this contract.
9. Virtual completion: date of virtual completion is the date when the construction is sufficiently completed in accordance with the contract documents, including modifications, if any.
10. Contract documents: shall consist of the following:
  - a) The agreement.
  - b) The General and Special conditions of contract.
  - c) The Bill of Quantities.
  - d) The drawings & specifications.
  - e) The approved makes.

### TYPE OF CONTRACT

It is an item rate contract. The Contractor shall be paid for the actual quantity and quality of work done, as measured at site on the rates quoted by him, on the basis of a payment certificate issued by the Architect/ Engineer- In charge.

### SCHEDULE OF QUANTITIES

Schedules of quantities given in the contract bill are provisional and are meant to indicate the intent of the work and to provide a uniform basis for the contract. The Owner reserves the right to increase or decrease any of the quantities or to totally omit any of them. Contractor shall be bound to carry out the same without claiming any extras.

## **CONTRACT DRAWINGS**

1. In general, drawings shall indicate dimension, position & type of construction.
2. Specifications shall indicate the qualities, methods, and bill of quantities shall indicate the quantum and rates. Any work indicated in drawings and not mentioned in the specifications or vice versa shall be furnished as fully set forth in both.
3. Contractor shall not deviate from the drawings and Architect's interpretation of the drawings shall be final and without appeal.
4. Errors/inconsistencies discovered in the drawings shall be instantly brought to the notice of the Architect for interpretation and correction, if any.
5. All drawings are the property of the Architect and shall not be used on any other project.

## **ARCHITECTS INSTRUCTIONS**

If within seven days of receipt of written instructions from the Architect, requiring compliance with an instruction the Contractor does not comply hence-with, then the Owner may get the work executed through another agency at the risk and cost of the Contractor.

## **SCOPE OF WORK OF CONTRACTOR**

The scope of work to be carried out by the CONTRACTOR shall also include the following:

1. Setting out of the works in respect of position, level dimensions, alignments, etc. including establishment of benchmarks, survey reference points, etc.
2. Clearance of the site.
3. Site levelling /terracing within the limits as shown in the drawings or as directed by the Engineer In charge.
4. Disposal of debris, excavated materials, etc. as per the instructions of the Engineer In-Charge
5. All scaffolding, shorting, cantering, shuttering works, etc.
6. Running and maintenance of all plants and equipment, tools and tackles, etc.
7. Any other work required in connection with the execution of the contract work.

The cost of all the above-mentioned works shall be deemed to be included in the rates for various items of work although such inclusion may not be specifically spelt out.

## **SAMPLES AND SHOP DRAWINGS**

The Contractor shall submit samples of materials and shops drawings required by the Architect with promptness within a week.

## **PROGRESS CHART**

In order to achieve the completion time as stated above, the CONTRACTOR shall submit to the OWNER within 2 (two) days from the effective date of Agreement a detailed Bar chart/PERT Network. The list of activities for which the Bar chart/ PERT network has been worked out and their commencement, duration and completion shall be subject to the approval of the OWNER

## **ACCESS FOR ARCHITECT/ ENGINEER IN CHARGE TO THE WORKS**

The Architect and his representative shall have access, at all reasonable times, to the work and workshops of the Contractor.

## **ARCHITECTS STATUS AND DECISIONS**

The Architect shall be Owner's representative during the construction period. He shall periodically visit the site to familiarize himself generally with the progress and the quality of work and to determine, in general if the work is proceeding in accordance with the contract documents. The Architect shall not be required to make exhaustive or continuous on-site inspections to check the quality and quantity of the work, and shall not be responsible for the Contractors failure to carry out the construction work in accordance with the contract documents. During his site inspections the Architect shall inform the Owner about progress of work, defects and deficiencies if any.

The Architect may in his absolute discretion from time to time, issue further drawings, details, written instructions, written decisions and written explanations in regard to: -

1. Variation or modification of the design
2. Quality or quantity of work, addition/alteration/omissions and substitutions of any work
3. Any discrepancy and divergence between drawings and specifications.
4. Removal and re-erection of any works executed by the Contractor
5. Dismissal of any persons employed on the site, who in the opinion of the Architect is not fit for the job.
6. Opening up for inspection any work-covered up
7. Amending and making good any defects under defects liability period
8. Removal from site, any materials brought by the Contractor, which in the opinion of the Architect is not up to the desired standard.
9. Delay and extension of time
10. Postponement of any work

## **ENGINEER IN CHARGE**

Engineer In-Charge shall mean a competent engineer appointed and paid by the Owner and acting in congruence with the Architect.

## **CONTRACTORS FIELD ORGANIZATION AND EQUIPMENT**

1. The Contractor shall employ qualified and competent licensed Electricians on the site.
2. Contractor shall provide and install all necessary hoists, ladders, scaffoldings, tools, tackles, plants and machinery necessary for execution of the works
3. Contractor shall provide and maintain simple watertight office accommodation at site
4. Contractor shall make his own security arrangements at site and keep a 24-hour Watchman
5. Contractor shall provide sanitary convenience for site staff and labour to keep the site clean

6. A telephone line at site to be maintained and paid by the Contractor
7. Guardrails shall be provided by the Contractor for safety of labour and general public at the site of works.

## **TAXES**

All taxes including GST, Labour Cess etc. applicable in respect of this contract shall be payable by the Contractor and PRINCIPAL, RAM LAL ANAND COLLEGE. will not entertain any claim whatsoever in respect of the same.

## **STATUTORY OBLIGATIONS**

The Contractor shall comply with and give all notices required by any Govt. authority and instrument, rule or order made under an act of parliament or state assembly or any regulation or bye-law of the local body, relating to the work and indemnify the Owner against any such liability arising out of noncompliance of the law.

By way of illustration of various Acts/statutory compliances as stated above, the following Acts as amended from time to time shall be complied with by the CONTRACTOR:

1. Employee's Provident Fund Act 1952
2. Contract Labour Act (Regulations and Abolition 1970)
3. Minimum Wages Act 1948
4. Payment of Wages Act 1936
5. Workmen Compensation Act 1923
6. Factories Act 1948
7. Apprenticeship Act 1961

## **SUB CONTRACTOR**

Before awarding any subcontract, the Contractor shall notify Architect/Engineer In-Charge in writing the names of the Sub-Contractors proposed. Contractor shall not employ the Sub-Contractor to whom Architect or Engineer In Charge may have a reasonable objection.

## **MEASUREMENT OF WORK**

Unless otherwise specified, measurement of work shall be carried from the works actually executed. The measurements for the purpose of preparing Bills will be taken jointly by the Contractor's representative and the Engineer In charge. In measurement of work as stated above, the CONTRACTOR shall certify that the work has been carried out strictly as per the drawings, specifications and item of work in terms of the agreement. Such certificate shall require Engineer In-Charge's endorsement for the purpose of payment.

In the event of any dispute with regard to the measurement of the work executed, the decision of the OWNER shall be final and binding on the CONTRACTOR.

In the case of site measurements, should the CONTRACTOR not attend or neglect or fail to send his representative for taking joint measurements, the measurements taken by the Engineer



in Charge shall be deemed to be the correct measurement of work and shall be binding on the CONTRACTOR.

### **REJECTION**

If the Contract work or any portion thereof, at any time, is found to be defective or fails to fulfil the requirements of the agreement, the Engineer In Charge shall give the CONTRACTOR notice in writing setting-forth particulars of such defects or failure and the CONTRACTOR shall forthwith make good the defects or replace or alter the same to make it comply with the requirements of the agreement.

Any materials, equipment, etc. brought to the site and found to be not in accordance with the agreement, shall be rejected by the Engineer In-Charge and the CONTRACTOR shall remove the materials from the site within the period specified by the Engineer In-Charge.

The CONTRACTOR shall not be entitled to any extension of time or extra cost for rejection as per above.

### **CERTIFICATES OF PAYMENTS**

Architect/Engineer In-Charge shall issue an interim certificate of payment stating the amount due to the Contractor from the Owner and the Contractor shall be entitled to payment thereof within a period of two week after issue of the certificate. From the total amount, certified deduction shall be made towards payments already made, security deposit, TDS etc. As applicable to Delhi or any other tax applicable at the time of making payment.

All running payments shall be regarded as payment by way of advance against final payment only and not as payment for the work completed till the date of final payment. The running payment made shall not preclude the liability of the CONTRACTOR to finally complete the work strictly in accordance with the specifications and drawings, if required by re-constructing faulty work

### **CLAIM FOR EXTRA**

In the case of extra item(s) (items that are completely new, and are in addition to the items contained in the contract), the contractor will submit rates, supported by rate analysis, for the work and the engineer-in-charge shall within one month of the receipt of the rates supported by rate analysis, after giving consideration to the analysis of the rates submitted by the contractor, determine the rates on the basis of the market rates and the contractor shall be paid in accordance with the rates so determined.

### **DEDUCTION FOR UNCORRECTED WORK**

If the Architect/ Engineer In-charge deems it in-expedient to correct work damaged or not done in accordance with the contract, an equitable deduction from the contract price shall be made thereof.

## **FLUCTUATIONS**

The Contractor shall not claim any extras for fluctuation of price and the contract price shall not be subjected to any rise or fall in prices.

## **POSSESSION BEFORE VIRTUAL COMPLETION**

If the Owner, with the consent of the Contractor takes possession of part of the works for handing over to the finishing Contractor, such part of the building shall not be deemed to be virtually completed. Virtual completion of such part would occur only on completion of every part of the contract work.

## **TIME EXTENSION**

Upon it becoming reasonably apparent that the progress of the work is delayed, the Contractor shall forthwith give written notice of the cause of delay to the Architect/ Engineer In charge, to enable the Architect and Owner to take a proper decision in the matter.

## **INSPECTION AND TEST**

1. The CONTRACTOR shall ensure inspection and test of all materials and work at his cost through his ENGINEER IN CHARGE and other technical staff either at site or through any approved laboratory.
2. The CONTRACTOR shall ensure proper supervision and inspection during the progress of work at site.
3. All materials and work, whether at the site or in the Contractor's /Sub-Contractor's premises shall be subject to inspection and test by the ENGINEER IN CHARGE. The CONTRACTOR/ his Sub-Contractor shall provide all facilities free of cost to the ENGINEER IN CHARGE including all labour, materials, tools, tackles, instruments, appliances, etc. to enable the ENGINEER IN CHARGE to carry out inspection and/or test.
4. All test certificates shall be subject to certification by the ENGINEER IN CHARGE.
5. The CONTRACTOR shall submit to the ENGINEER IN CHARGE three copies of all inspection/ test certificates.
6. The CONTRACTOR shall not be entitled to any claim for extra time or cost due to any delay in carrying out inspection and testing or re-inspection and re-testing if so, decided by the ENGINEER IN CHARGE.
7. The CONTRACTOR shall take adequate steps to rectify the defects or to replace such materials and work which have failed during inspection /testing.

## **RESPONSIBILITY OF COMPLETION**

Any work supplies or services which might have not been specifically mentioned in the specifications, schedule of items or drawings but are necessary for entire completion of the contract work shall be executed / provided/ rendered by the CONTRACTOR without any Extra

cost and within the time schedule specified. Rates quoted shall be deemed to include such elements of labour and materials necessary to complete the items of work in all respects.

### **DAMAGES FOR NON-COMPLETION**

If the Contractor fails to complete the works by the date specified or within any extended time granted to him, the Contractor shall allow the Owner to deduct a sum calculated at the agreed liquidated damages, from the money due to him for the period the work remained incomplete, subject to a maximum amount of 10% of the Contract Value.

### **LIQUIDATED DAMAGES FOR DELAY**

If the CONTRACTOR fails to complete the work/item (s) of work in all respects and hand over the same to the OWNER within the time stipulated the CONTRACTOR, without prejudice to any other right or remedy of the OWNER on account of such breach, be liable to pay the OWNER liquidated damages at the rate of Rs. 5,000/- (Five Thousand) per day of delay. The total amount of liquidated damages shall be limited to 10% (Ten percent) of the total contract price.

The above provisions shall not apply in cases of delay for which the CONTRACTOR is entitled to extension of completion time

### **VIRTUAL COMPLETION CERTIFICATE AND DEFECTS LIABILITY PERIOD**

When in opinion of the Architect/Engineer In charge the works are practically completed, he shall forthwith issue a certificate to that effect, that date will be taken as the date of virtual completion.

The Architect/Engineer In charge shall prepare a schedule of defects, not later than 14 days after the expiry of the defect's liability period. The Contractor shall within a reasonable period of time after receipt of schedule of defects shall rectify the same, failing which the Architect/Engineer In charge will make suitable deductions from the contract sum.

### **MAINTENANCE GUARANTEE / DEFECTS LIABILITY PERIOD**

Maintenance Guarantee period will be 24 months from the actual date of completion and handing over to the OWNER.

1. The CONTRACTOR guarantees that within the maintenance guarantee period, the contract work shall not show any signs of defects, cracks, settlements, disfigurements, shrinkage, leakage, dampness, or any other defects.
2. The CONTRACTOR shall maintain and satisfactorily execute, at his own cost, all such works of repair, amendment, re-construction, rectification, replacement, and any other work to make good the faulty work as stated in Article (a) during the maintenance guarantee period.
3. The CONTRACTOR shall, if required by the ENGINEER IN CHARGE, search for the causes of any defects, imperfection, or fault under the direction of the ENGINEER IN CHARGE. The cost of such search shall be borne by the CONTRACTOR.

4. At intervals specified by the ENGINEER IN CHARGE the CONTRACTOR, along with the ENGINEER IN CHARGE, shall inspect the contract work to satisfy himself that no defects have cropped up in the contract work. Should there be any signs of defects, the CONTRACTOR shall take immediate steps to rectify the same, failing which; the ENGINEER IN CHARGE may get the defects rectified at the risk and cost of the CONTRACTOR.
5. At the end of the maintenance guarantee period, the CONTRACTOR, along with the ENGINEER IN CHARGE, shall carry out final inspection of the contract work to prove that no defects had appeared in the contract work or that all defects which appeared in the contract work have been rectified to the entire satisfaction of the ENGINEER IN CHARGE. If during the final inspection it is found that the defects still remain in the contract work, the period of maintenance guarantee shall be extended at the discretion of the ENGINEER IN CHARGE and the CONTRACTOR shall be liable to make good the defects and be responsible for the maintenance of the work till the defects have been fully rectified.
6. Upon successful completion of the maintenance guarantee period the OWNER shall issue final acceptance certificate to the CONTRACTOR

#### **PAYMENT WITH HELD**

The Architect may withhold or on account of subsequently discovered evidence nullify the whole or part of any certificate to such an extent as may be necessary in his reasonable opinion to protect the Owner from loss, for defective work, non- payment to Subcontractors, or other claims connected to this work.

#### **INJURY TO PERSONS**

The Contractor shall indemnify the Owner against any liability, loss, claim or proceedings whatsoever arising under any statutory or common law in respect of personal injury to or the death of any person, whomsoever arising out of or in the course of or caused by carrying out the work.

#### **INSURANCE**

Without prejudice to his ability to indemnify the Owner, the Contractor and his Subcontractors shall maintain such insurance as are necessary to cover the liability of the Contractor and the sub-Contractors.

#### **INSURANCE AGAINST FIRE**

The Contractor shall in the joint name of the Owner and the Contractor, insure the works against loss or damage due to fire, earthquakes, and riots.

#### **COORDINATION OF WORK**

Contractor shall extend complete coordination to other agencies i.e. electrical, firefighting and interiors working on the same site.

## **LABOUR**

Contractor shall not employ child labour under 14 years of age and if female workers are employed, he should make provision for safeguarding the small children to keep them clear of the site. All labour shall wear safety helmets and shoes to protect them from injury.

## **SAFETY**

In respect of all labour directly or indirectly employed in the work for the performance of the contractor's part of this contract, the contractor shall at his own expense arrange for the safety provisions as per C.P.W.D. Safety Code framed from time to time and shall at his own expense provide for all facilities in connection therewith. In case the contractor fails to make arrangement and provide necessary facilities as aforesaid, he shall be liable to pay a penalty of Rs.200/- for each default and in addition, the Engineer-in- Charge shall be at liberty to make arrangement and provide facilities as aforesaid and recover the costs incurred in that behalf from the contractor.

## **GUARANTEE**

Besides guarantees required elsewhere, the Contractor shall guarantee the works in general for one year after completion of defects liability period.

## **PERFORMANCE GUARANTEE**

In addition to the Security Deposit the Contractor shall furnish a performance guarantee in the form of a Bank Guarantee to the tune of Five percent (5%) of the cost of the tender amount, which will be kept valid up to 24 months after completion of the work.

## **WARRANTY**

The Contractor shall give warranty that works to be done supplied shall be new and free from all defects and faults in material, workmanship, and manufacture and shall be of the highest grade and consistent with the established and generally accepted standards for materials of the type ordered and shall perform in full conformity with the specifications and drawings. The Contractor shall be responsible for any defects that may develop under the conditions provided by the contractor and under proper use, arising from faulty materials, design or workmanship such as corrosion of the equipment, inadequate contact protection, deficiencies in design and or otherwise and shall remedy such defects at his own cost when called upon to do so by the Institute who shall state in writing in what respect goods are faulty. This shall survive inspection or payment for, and acceptance of goods, after the goods have been taken over.

If it becomes necessary for the contractor to replace or renew any defective Portion / portions of the equipment under this clause, the provisions of the clause shall apply to the portion / portions of equipment's replaced or renewed or until the end of the warranty period of 24 months, whichever may be later. If any defect is not remedied within a reasonable time, the College may proceed to get the work done at the Contractor's risk and expenses, but without

prejudice to any other rights which the College may have against the Contractor in respect of such defects. Replacement under warranty clause shall be made by the Contractor free of all charges at site including freight, insurance and other incidental charges

### **REPLACEMENT OF DEFECTIVE EQUIPMENT**

If any equipment or any part thereof, is found defective or fails to meet the requirements of the contract before it is accepted College shall give the Contractor a notice setting forth details of such defects or failures and the Contractor shall forthwith arrange to set right the defective equipment or replace the same by the good one to make it comply with the requirements of the contract. This in any case shall be completed within a period not exceeding one month from the date of the initial report pointing out the defects. The replacement or rectification shall be made at site by the Contractor free of cost. Should the Contractor fail to do the needful within this stipulated time frame, the College reserves the right to reject the equipment in full or in part and get it replaced at the cost of the Contractor. The cost of any such replacement made by the College shall be deducted from the amount payable to the Contractor against this purchase order.

If any equipment or part thereof is lost or rendered defective during transit, pending settlement of the insurance claim, fresh order shall be placed on the Contractor for such loss or defective equipment and the Contractor shall arrange to supply the same within three months of such order at the same prices and on the same general terms and conditions as mentioned in this purchase order.

### **ADD ON ORDER**

PRINCIPAL, RAM LAL ANAND COLLEGE. reserves the right to place Add on order for additional quantity up to 100% of the original quantity at the same rate and terms & conditions of the purchase order within six months from the date of issue of purchase order.

### **ARBITRATION**

In case of dispute, the difference of opinion on any matter pertaining to the works, the decision of the PRINCIPAL, RAM LAL ANAND COLLEGE. be final and binding on the contractors. If either party is not satisfied with the decision of the PRINCIPAL, RAM LAL ANAND COLLEGE., within 28 days a notice to this effect will be sent to the PRINCIPAL, RAM LAL ANAND COLLEGE. in writing. The matter can then be referred to a sole arbitrator or a panel of two arbitrators appointed under the arbitration act 1996.

### **LIQUIDATION**

If the CONTRACTOR commences to be wound up, not being a member's voluntary winding up for the purpose of amalgamation or reconstruction, or carries on his business under a receiver for the benefits of his creditor the OWNER shall be at liberty to:

- i) Give such receiver the liquidator or other person the option of carrying out the performance under the Agreement, subject to the receiver, liquidator or other person providing a guarantee

up to an amount to be agreed upon by the OWNER and such receiver liquidator or other person for the due and faithful performance of the Contractor's obligations under this Agreement, or

ii) If the receiver, liquidator or other person fails within 30 (thirty) days to exercise the option to carry out performance of the Agreement then the OWNER may terminate the Agreement and give notice in writing to the CONTRACTOR or to the receiver, liquidator or to any person in whom the Agreement may have become vested.

### **TERMINATION OF CONTRACT**

If the CONTRACTOR violates the Agreement or shall neglect to execute the work with due diligence or expedition or shall refuse or neglect to comply with any reasonable directions, instructions or orders given to him in writing by the Architect/Engineer In-Charge in connection with the work or shall contravene or breach any provisions of the Agreement, the OWNER may give notice in writing to the CONTRACTOR to make good the failure, neglect or contravention complained of or cure that breach within a period of 30 (thirty) days of receiving such notice and in default of the compliance with the said notice, the OWNER without prejudice to his rights as below may rescind or terminate the Agreement stating therein the effective date of termination, holding the CONTRACTOR liable for the damages that the OWNER may sustain in this behalf.

Without prejudice to any of the rights or remedies under this contract, if the contractor dies, the Owner shall have the option of terminating the contract without compensation to the CONTRACTOR.

### **OFFICIALS NOT TO BENEFIT**

The Contractor warrants that it has not and shall not offer any direct or indirect benefit arising from or related to the performance of the Contract or the award thereof to any representative, official, employee, or other person in the office of PRINCIPAL, RAM LAL ANAND COLLEGE. , Benito Juarez Road, New Delhi- 110 021. The Contractor acknowledges and agrees that any breach of this provision is a breach of an essential term of the Contract.

### **PENALTY FOR USE OF UNDUE INFLUENCE**

The contractor undertakes that he has not given, offered or promised to give, directly or indirectly, any gift, consideration, reward, commission, fees, brokerage or inducement to any person in service of the Buyer or otherwise in procuring the Contracts or for bearing to do or for having done or forborne to do any act in relation to the obtaining or execution of the present Contract.

Any breach of the aforesaid undertaking by the Contractor (Seller) or any one employed by him or acting on his behalf (whether with or without the knowledge of the Seller) or the commission of any offence by the, Seller or anyone employed by him or acting on his behalf, as defined in Chapter IX of the Indian Penal Code, 1860 or the Prevention of Corruption Act, 1986 or any other Act enacted for the prevention of corruption shall entitle the Buyer to cancel the Contract and all or any other Contracts with the Seller.

E-TENDER FOR CONSTRUCTION OF STEEL STAIRCASE AT RAM LAL ANAND COLLEGE, NEW DELHI. (2nd call)



**FORM OF PERFORMANCE SECURITY BANK GUARANTEE BOND**

In consideration of the PRINCIPAL, RAM LAL ANAND COLLEGE. (hereinafter called “The Owner”) having agreed under the terms and conditions of agreement no.

Dated:

---

Made between the Owner and

---

(hereinafter called “the Said Contractor(s)) for the work of **E-TENDER FOR CONSTRUCTION OF STEEL STAIRCASE AT RAM LAL ANAND COLLEGE, NEW DELHI. (2nd call)** herein after called “the said agreement”.

We (please mention name of the bank below)

---

Undertake to pay to The Owner an amount not exceeding Rupees

(In words)

---

On demand by The Owner.

2. We (please mention name of the bank below)

---

Do hereby undertake to pay the amounts due and payable under this Guarantee without any demure, merely on a demand from The Owner stating that the amount claimed is required to meet the recoveries due or likely to be due from the said contractor(s). Any such demand made on the Bank shall be conclusive as regards the amount due and payable by the bank under this Guarantee. However, our liability under this guarantee shall be restricted to an amount not exceeding Rupees

(In words)

---

3. We, the Said Bank further undertake to pay to The Owner any money so demanded notwithstanding any dispute or disputes raised by the Said Contractor(s) in any suit or proceeding pending before any court or tribunal relating thereto, our liability under this present being absolute and unequivocal.

The payment so made by us under this bond shall be a valid discharge of our liability for payment thereunder and the Said Contractors(s) shall have no claim against us for making such payment.

4. We (please mention name of the bank below)

---

Further agree that the guarantee herein contained shall remain in full force and effect during the period that would be taken for the performance of the said agreement and it shall continue to be enforceable till all the dues of The Owner under or by virtue of the said agreement have been fully paid and its claims satisfied or discharged or till Engineer-in-Charge on behalf of The Owner certified that the terms and conditions of the said agreement have been fully and properly carried out by the Said Contractor(s) and accordingly discharges this guarantee.

5. We (please mention name of the bank below)

---

Further agree with The Owner that The Owner shall have the fullest liberty without our consent and without effecting in any manner our obligations hereunder to vary any of the terms and conditions of the said agreement or to extend time of performance by the said contractor(s) from time to time or to postpone for anytime of from time to time any of the powers exercisable by The Owner against the said contractor(s) and to for-bear or enforce any of the terms and conditions relating to the sad agreement and we shall not be relived from our liability by reason of any such variation, or extension being granted to the Said Contractor(s) or for any forbearance, act of commission on part of The Owner or any indulgence by The Owner to the Said Contractor(s) or by any such matter or thing whatsoever which under the law relating to sureties would, but for this provision, have effect of so relieving us.

6. This guarantee will not be discharged due to the change in the constitution of The Bank or the Said Contractor(s)

7. We (please mention name of the bank below)

---

Lastly undertake not to revoke this guarantee except with the previous consent of The Owner in writing.

8. This Guarantee shall be valid upto \_\_\_\_\_. Unless extend on demand by The Owner. Notwithstanding anything mentioned above, our liability against this guarantee is restricted to Rupees

(In words)

---

And unless a claim in writing is lodged with us within six months of the sate of expiry of the extended date of expiry of this guarantee all our liabilities under this guarantee shall stand discharged.

Dated: the \_\_\_\_\_ day of \_\_\_\_\_ for \_\_\_\_\_ (Bank).

**TURNOVER CERTIFICATE (ANNEXURE 1)**

**ON THE LETTER PAD OF CHARTERED ACCOUNTANT**

**This is to certify that the total turnover of**

**M/s** \_\_\_\_\_

**Having PAN** \_\_\_\_\_

**is as under:**

<b>FINANCIAL YEAR</b>	<b>AMOUNT (FIGURES)</b>	<b>AMOUNT (WORDS)</b>
<b>2019-2020</b>		
<b>2020-2021</b>		
<b>2021-2022</b>		

**Average = Total/3 =** \_\_\_\_\_

**It is further certified that the above-mentioned amounts have been derived from the books of accounts presented before us for the above-mentioned periods.**

**Stamp and Signature of Chartered Accountant.**

**LIST OF APPROVED MAKES FOR CIVIL WORKS**

<b>Approved Make of Materials</b>		
(Applicable wherever the make is not listed in the item)		
<b>S.No</b>	<b>Materials</b>	<b>Manufacturer</b>
1)	Commercial Ply and Commercial Board	Duro, Greenply, Virgo , Merino
2)	Teak Ply	Duro, Greenply, Virgo, Merino
3)	Laminate	Greenlam, Virgo, Merino, Sundek
4)	Mirror	Modigaurd, Saint Gobain
5)	Glass	Modigaurd, Saint Gobain
6)	Flush Door Shutters	Duro, Green, Virgo, Merino
7)	Paints	Nerolac, Dulux, Asian, Berger
8)	Mortice Latches And Locks	Godrej, Dorset, Hardwyn, Ebco, Hettich, Hafele.
9)	Coarse Sand	As Per Is:383 (Latest Edition) Approved Quarry Or Equivalent
10)	Fine Sand	Do.
11)	Stone Aggregate	Do.
12)	Aluminium Section	Jindal/ Hindalco.
13)	Wall and Floor Tiles	Orient, Kajaria, Nitco, Johnson, Somany, Asian.
14)	Mdf Board	Century Prowud, Greenpanel, VIR.
15)	Hinges- Ms Oxidised / SS	Godrej, Dorset, Hardwyn, Ebco, Hettich, Hafele.
16)	Tower Bolt	Godrej, Dorset, Hardwyn, Ebco, Hettich, Hafele.
17)	Door Stopper	Godrej, Dorset, Hardwyn, Ebco, Hettich, Hafele.
18)	L-Drop	Godrej, Dorset, Hardwyn, Ebco, Hettich, Hafele.
19)	Handles and locks	Godrej, Dorset, Hardwyn, Ebco, Hettich, Hafele.
20)	Pvc Strips/ Hand Rail /Railing	Fixo Pan , Sun, Kelco, S-Rail,
21)	Cement: OPC 43 / 53	Ultratech, L&T, Ambuja, JK Laxmi, ACC.
22)	Steel	Tata, Sail, RNIL, Rathi Thermax 500.

**CONTRACT DRAWINGS**

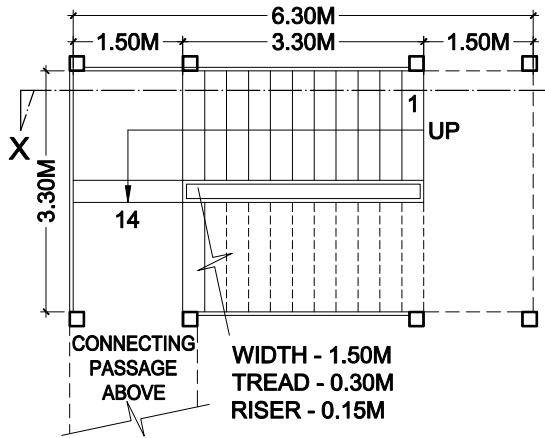

INTERNAL ROAD TO GROUND FLOOR STAIRCASE PLAN

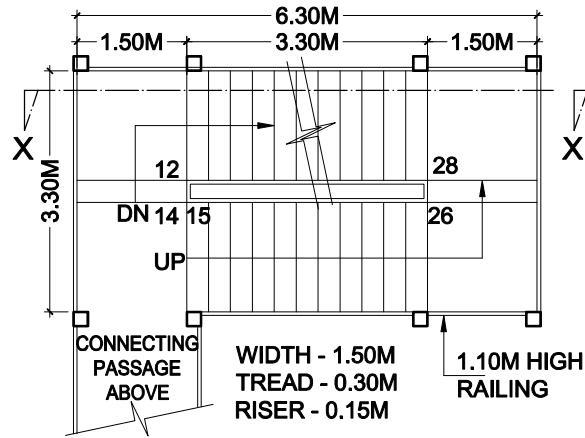

GROUND TO FIRST FLOOR STAIRCASE PLAN

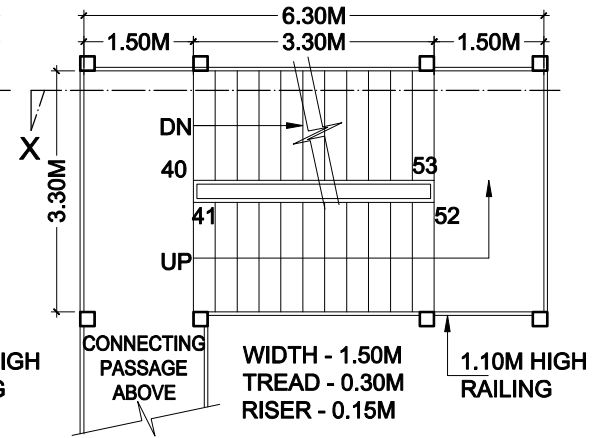

FIRST TO SECOND FLOOR STAIRCASE PLAN

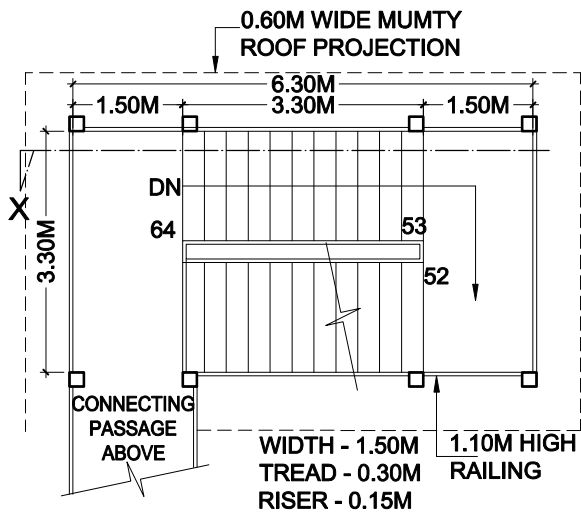

SECOND FLOOR STAIRCASE PLAN

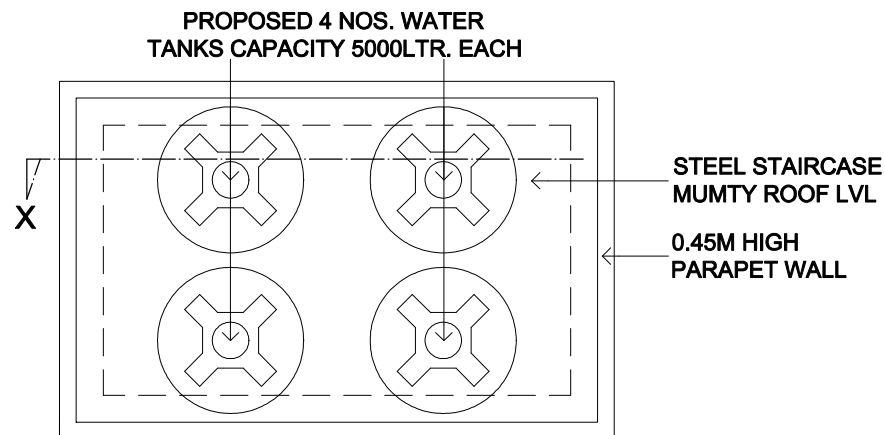

PROJECT:

E-TENDER FOR CONSTRUCTION OF STEEL STAIRCASE AT RAM LAL ANAND COLLEGE, NEW DELHI

Delhi University South Campus  
Benito Juarez Road, New Delhi- 110 021

Date : 20/06/2023

Scale : NTS

Drawn By : SANJAY

Copy Right : RSA

Sheet No.

1

Sheet Title

FLOOR PLANS

**RANJIT SINGH & ASSOCIATES**

1206 Surya Kiran Building, 19 K.G. Marg, New Delhi 110001  
Ph.23312688 Fax: 51510129 Email: rsa1206@msn.com



Architects, Engineers & Interior Designers  
Govt. approved Valuers and House Tax Consultants

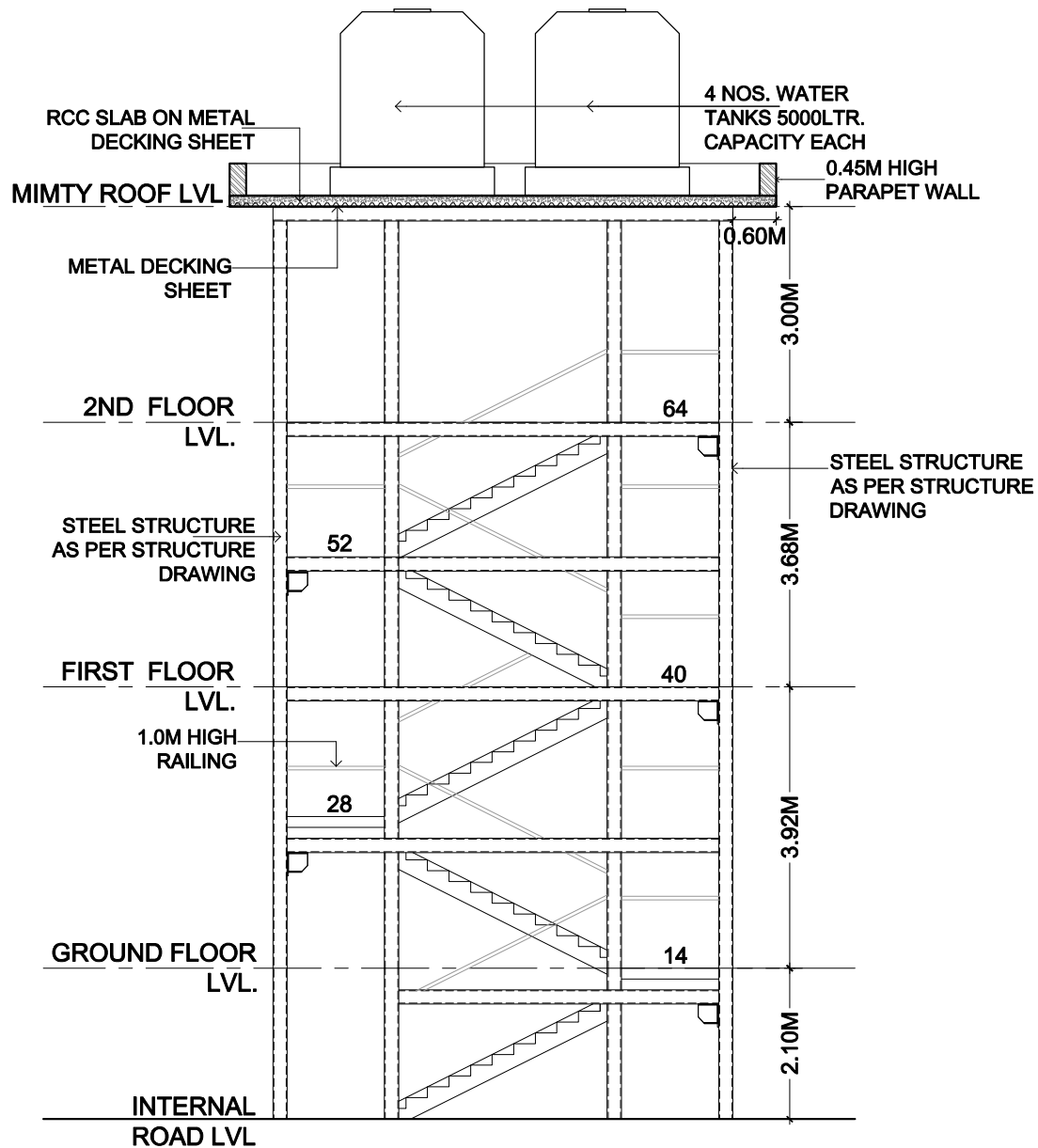

SECTION - "X"

PROJECT:

**E-TENDER FOR CONSTRUCTION OF STEEL STAIRCASE AT RAM LAL ANAND COLLEGE, NEW DELHI**

Delhi University South Campus  
Benito Juarez Road, New Delhi- 110 021

Date : 20/06/2023

Scale : NTS

Drawn By : SANJAY

Copy Right RSA

Sheet No.

**2**

Sheet Title

**SECTION**

**RANJIT SINGH & ASSOCIATES**

1206 Surya Kiran Building, 19 K.G. Marg, New Delhi 110001  
Ph.23312688 Fax: 51510129 Email: rsa1206@msn.com

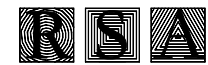

Architects, Engineers & Interior Designers  
Govt. approved Valuers and House Tax Consultants

## SCHEDULE OF WORK

Sl. No.	Item Description	Quantity	Units	Rate	RATE WITH TAXES	TOTAL AMOUNT With All Taxes
1	<b>NOTE: ITEMS MENTIONED AS 0 (ZERO) QUANTITY ARE RATE ONLY ITEMS. PLEASE QUOTE THE RATES FOR THOSE ITEMS.</b>  <b>CIVIL WORKS</b>					
1.01	Earth work in excavation by mechanical means (Hydraulic excavator)/manual means over areas (exceeding 30 cm in depth, 1.5 m in width as well as 10 sqm on plan) including getting out and disposal of excavated earth lead upto 50 m and lift upto 1.5 m, as directed by Engineer-in charge	24.000	CUM			0.00
1.02	Filling available excavated earth (excluding rock) in trenches, plinth, sides of foundations etc. in layers not exceeding 20cm in depth, consolidating each deposited layer by ramming and watering, lead up to 50 m and lift upto 1.5 m.	9.000	CUM			0.00
1.03	Dismantling old plaster or skirting raking out joints and cleaning the surface for plaster including disposal of rubbish to the dumping ground within 50 metres lead.	200.000	SQM			0.00
1.04	Chipping of unsound/weak concrete material from slabs, beams, columns etc. with manual Chisel and/ or by standard power driven percussion type or of approved make including tapering of all edges, making square shoulders of cavities including cleaning the exposed concrete surface and reinforcement with wire brushes etc. and disposal of debris for all lead and lifts all complete as per direction of Engineer-In-Charge 25 mm average thickness.	75.000	SQM			0.00
1.05	Demolishing R.C.C. work manually/ by mechanical means including stacking of steel bars and disposal of unserviceable material within 50 metres lead as per direction of Engineer - in- charge.	2.000	CUM			0.00
1.06	Extra for cutting reinforcement bars manually/ by mechanical means in R.C.C. or R.B. work (Payment shall be made on the cross sectional area of R.C.C. or R.B. work) as per direction of Engineer in-charge.	2.000	SQM			0.00
1.07	Extra for scrapping, cleaning and straightening reinforcement from R.C.C. or R.B. work	500.000	KG			0.00
1.08	Demolishing brick work manually/ by mechanical means including stacking of serviceable material and disposal of unserviceable material within 50 metres lead as per direction of Engineer-in-charge.	3.000	CUM			0.00
1.09	Dismantling doors, windows and clerestory windows (steel or wood) shutter including chowkhats, architrave, holdfasts etc. complete and stacking within 50 metres lead :	5.000	EACH			0.00
1.1	Dismantling steel work in built up sections in angles, tees, flats and channels including all gusset plates, bolts, nuts, cutting rivets, welding etc. including dismembering and stacking within 50 metres lead	500.000	KG			0.00
1.11	Dismantling stone slab flooring/ Tile flooring/ Paver flooring laid in cement mortar including removing the cement mortar from the sub-surface, stacking of serviceable material and disposal of unserviceable material within 50 metres lead.	50.000	SQM			0.00
1.12	Disposal of building rubbish / malba / similar unserviceable, dismantled or waste materials by mechanical means, including loading, transporting, unloading to approved municipal dumping ground or as approved by Engineer-in-charge, beyond 50 m initial lead, for all leads including all lifts involved.	30.000	CUM			0.00
1.13	Brick work with common burnt clay modular bricks of class designation 7.5 in foundation and plinth in Cement mortar 1:4 (1 cement : 4 coarse sand)	3.000	CUM			0.00



1.14	Brick work with common burnt clay F.P.S. (non modular) bricks of class designation 7.5 in superstructure above plinth level up to floor V level in all shapes and sizes in : Cement mortar 1:6 (1 cement : 6 coarse sand)	3.000	CUM			0.00
1.15	Providing and laying in position cement concrete of specified grade excluding the cost of centering and shuttering - All work up to plinth level: 1:4:8 (1 Cement : 4 coarse sand : 8 graded stone aggregate 40mm nominal size)	4.000	CUM			0.00
1.16	Providing and laying in position specified grade of reinforced cement concrete, excluding the cost of centering, shuttering, finishing and reinforcement - All work up to plinth level : 1:1.5:3 (1 cement : 1.5 coarse sand (zone-III) derived from natural sources : 3 graded stone aggregate 20 mm nominal size derived from natural sources)	10.000	CUM			0.00
1.17	Reinforced cement concrete work in beams, slabs, suspended floors, roofs having slope up to 15° landings, balconies, shelves, chajjas, lintels, bands, plain window sills, staircases and spiral stair cases above plinth level up to floor five level, excluding the cost of centering, shuttering, finishing and reinforcement with 1:1.5:3 (1 cement : 1.5 coarse sand(zone-III) derived from natural sources : 3 graded stone aggregate 20 mm nominal size derived from natural sources).	3.000	CUM			0.00
1.18	Steel reinforcement for R.C.C. work including straightening, cutting, bending, placing in position and binding all complete all Levels. Thermo-Mechanically Treated bars. (Only TATA Or SAIL)	1560.000	CUM			0.00
1.19	Centering and shuttering including strutting, propping etc. and removal of form for all works at all levels: Foundations, footings, bases of columns, Walls (any thickness) including attached pilasters, buttresses, plinth and string courses etc. Suspended floors, roofs, landings, balconies and access platform, Lintels, beams, plinth beams, girders, bressumers and cantilevers, Columns, Pillars, Piers, Abutments, Posts and Struts, Stairs, (excluding landings) except spiral-staircases, Weather shade, Chajjas, corbels etc., including edges	95.000	SQM			0.00
1.2	Providing & Fixing in position Metal Decking Sheets ( Pennar/ CRIL Deckspan/ Tata Bluscope/ inter arch roofing/ raj mohan) roofing 1.0 mm thk @ minimum 10.34 kg per sq.m for supporting RCC Slab (permanent shuttering) including edge trims cutting, trimming, fixing, leak proofing of joints etc. complete.	40.000	SQM			0.00
1.21	Structural steel work : Steel work in built up tubular (round, square or rectangular hollow tubes etc.) trusses etc., including cutting, hoisting, fixing in position and applying a priming coat of approved steel primer, including welding and bolted with special shaped washers etc. complete.  The contractor shall submit a Shop drawing of the Staircase Structure along with a Structure Stability Certificate for the structure issued by a registered structure engineer along with a copy of the registration certificate of the structure engineer	5996.000	KG			0.00
1.22	Steel work welded in built up sections/ framed work, including cutting, hoisting, fixing in position and applying a priming coat of approved steel primer using structural steel etc. as required.: In stringers, treads, landings etc. of stair cases, including use of 4mm thick chequered plate wherever required, all complete	1788.000	KG			0.00
1.23	Steel work welded in built up sections/ framed work, including cutting, hoisting, fixing in position and applying a priming coat of approved steel primer using structural steel etc. as required.: In gratings, frames, guard bar, ladder, railings, handrail brackets, gates and similar works	979.000	KG			0.00
1.24	BRICK COBA WATERPROOFING COMPLETE AS PER DSR 2021 ITEM NO. 22.7.1 Providing and laying integral cement based waterproofing treatment including preparation of surface as required for treatment of roof, balconies, terraces etc consisting of following operations With average thickness of 120 mm and minimum thickness at khurra as 65 mm.	40.000	SQM			0.00
1.25	18 mm cement plaster in two coats under layer 12 mm thick cement plaster 1:5 (1 cement : 5 coarse sand) finished with a top layer 6 mm thick cement plaster 1:6 (1 cement : 6 fine sand).  (Junctions of all RCC and brick shall be provided with chicken wire mesh of 150 mm width on either side of the junction before plastering)  All concrete and brick joints have to be given groove in plast	115.000	SQM			0.00
1.26	External painting works: External painting works at all heights and levels as per procedure mentioned including 1) Surface preparation (scrapping, sanding, cleaning)	115.000	SQM			0.00

	<p>2) A liberal coat of Wall Primer as per manufacturers specification</p> <p>3) Painting 2 or more coats of Exterior Weather Proof Paint in various colors (Asian/ ICI /Shalimar/ Berger/ Nerolac)</p> <p>4) Horizontal surfaces like the tops of chajjas and parapets must be given an additional coat for greater protection</p> <p>Contractor's scope includes all materials, tools &amp; plants, paint brushes &amp; rollers of approved makes, ropes, lifts, ladders, safety equipment's, scaffolding and all other equipment's as may be required to complete the works successfully. (The rates include all labour, materials and items of work required to complete the work successfully up to the satisfaction of the owner)</p>					
1.27	<p>Painting with synthetic enamel paint of approved brand and manufacture of required colour to give an even shade :</p> <p>Two or more coats on new work</p>	200.000	SQM			<b>0.00</b>
1.28	<p>Providing and fixing double scaffolding system (cup lock type) on the exterior side, up to seven story height made with 40 mm dia M.S. tube 1.5 m centre to centre, horizontal &amp; vertical tubes joining with cup &amp; lock system with M.S. tubes, M.S. tube challies, M.S. clamps and M.S. staircase system in the scaffolding for working platform etc. and maintaining it in a serviceable condition for the required duration as approved and removing it there after .The scaffolding system shall be stiffened with bracings, runners, connection with the building etc wherever required for inspection of work at required locations with essential safety features for the workmen etc. complete as per directions and approval of Engineerin-charge .The elevational area of the scaffolding shall be measured for payment purpose .The payment will be made once irrespective of duration of scaffolding.</p>	396.000	SQM			<b>0.00</b>